

# WPS1500

## QUICK REFERENCE GUIDE



Omnidirectional Imaging Scanner

**Wasp**  
BARCODE TECHNOLOGIES

---

## Wasp Barcode Technologies

1400 10th St.  
Plano, TX 75024  
Tel. 866-547-9277

©2020 Wasp Barcode Technologies and/or its affiliates

All rights reserved. Without limiting the rights under copyright, no part of this documentation may be reproduced, stored in or introduced into a retrieval system, or transmitted in any form or by any means, or for any purpose, without the express written permission of Wasp Barcode Technologies (referenced as Wasp) and/or its affiliates.

Owners of Wasp products are hereby granted a non-exclusive, revocable license to reproduce and transmit this documentation for the purchaser's own internal business purposes. Purchaser shall not remove or alter any proprietary notices, including copyright notices, contained in this documentation and shall ensure that all notices appear on any reproductions of the documentation.

Electronic versions of this document may be downloaded from the Wasp website ([www.waspbarcode.com](http://www.waspbarcode.com)). If you visit our website and would like to make comments or suggestions about this or other Wasp publications, please let us know via the "Contact" page.

### Disclaimer

Wasp has taken reasonable measures to provide information in this manual that is complete and accurate, however, Wasp shall not be liable for technical or editorial errors or omissions contained herein, nor for incidental or consequential damages resulting from the use of this material. Wasp reserves the right to change any specification at any time without prior notice.

### Trademarks

Wasp Barcode Technologies and the Wasp logo are registered trademarks of Wasp in many countries, including the U.S.A. and the E.U.

### Patents

See [www.waspbarcode.com](http://www.waspbarcode.com) for patent list.

### ORIGINAL VERSION

**See the Regulatory Addendum included with your product for additional regulatory, safety and legal information.**

# TABLE OF CONTENTS

---

<b>Quick Reference</b> .....	<b>1</b>
<b>Features</b> .....	<b>1</b>
German GS Safety Certification .....	3
<b>Installation</b> .....	<b>3</b>
Optional Stand/Riser.....	4
Removing the Stand/Bottom Cover .....	4
Magnetic Base Mounting.....	4
<b>How to Scan</b> .....	<b>5</b>
Handheld Scanning Mode.....	5
Center Zone Qualification .....	6
Scanner Button .....	6
Scanner Button Functions .....	6
<b>LED and Beeper Indicators</b> .....	<b>8</b>
<b>Programming</b> .....	<b>10</b>
Service Port Mode .....	10
Using Barcodes.....	10
Interface Selection .....	11
Good Read Green Spot Duration.....	12
Cell Phone Mode .....	13
Cell Mode Frequency .....	14
<b>Troubleshooting</b> .....	<b>15</b>
Error Codes .....	16
<b>Cleaning</b> .....	<b>17</b>
Manufacturer Approved Cleaning Materials.....	18
<b>Warranty</b> .....	<b>19</b>

---

# NOTES

# WPS1500

---

## QUICK REFERENCE

This guide is provided to help get your scanner up and running quickly and efficiently. For more details, including additional programming information, reference the Product Reference Guide (PRG), which is available from the Wasp website.

## FEATURES

**Figure 1. Scanner Features - Front View**

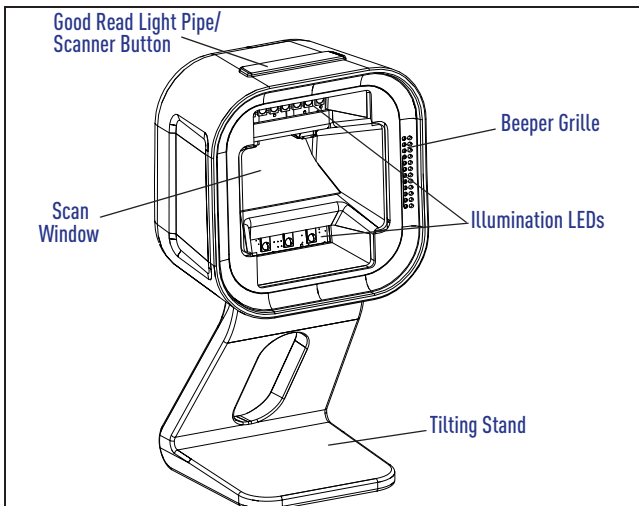

**Figure 2. Scanner Features - Bottom View**

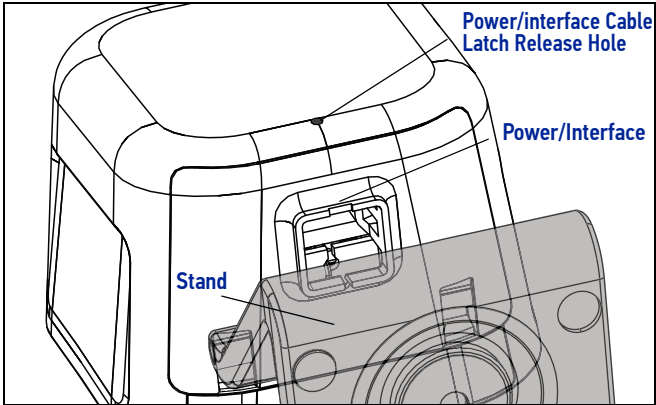

**Figure 3. Labeling**

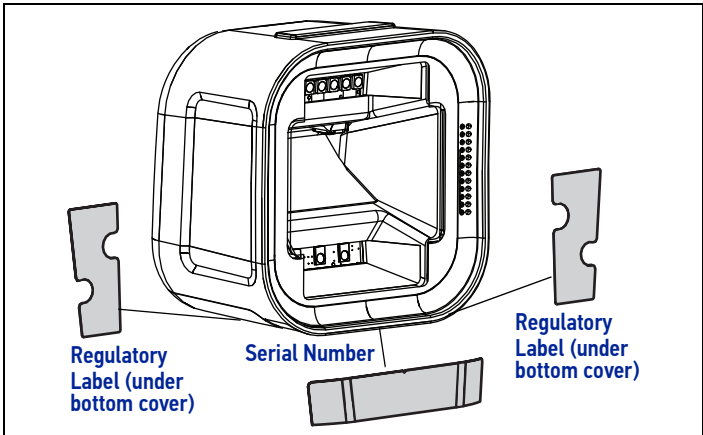

**NOTE**

Remove the stand/cover to view the Regulatory Labeling, as described on page 4. Labels are shown to illustrate their location only. Please view the labels on your product for actual details.

---

## German GS Safety Certification

The following statement is required for the German GS safety certification:

This product is not intended for use in the immediate or direct visual field of the display work place. To avoid disturbing reflections on the display work place, this product shall not be placed in the immediate or direct field of vision.

## INSTALLATION

Route the interface cable from the terminal or host. Plug the AC adapter (if one is used) into a wall outlet and the interface (I/F) cable, then route and attach the I/F cable to the scanner. Verify operation by presenting known-good bar codes to the scanner. The unit should beep<sub>1</sub> and/or flash its good read LED and send the bar code data to the host or terminal. If not, refer to the Troubleshooting section of this guide.

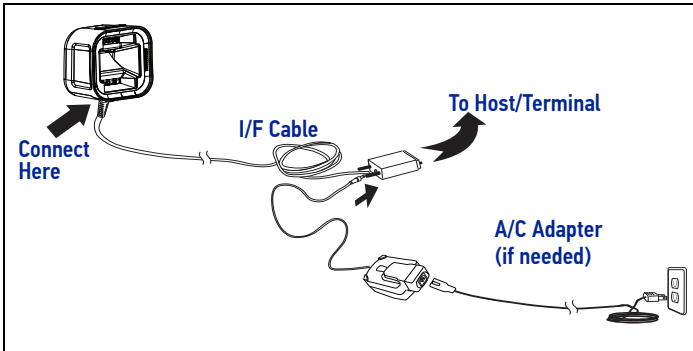

The WPS1500 uses intelligent illumination technology to optimize light levels for a variety of bar code scanner functions including automatic reading of bar codes from printed surfaces, mobile devices and image capture in variable contrast environments.

---

1. Beeper and LED behavior is selectable and may have been disabled by a previous user.

---

## Optional Stand/Riser

An optional stand / riser is available for the scanner. The stand and riser have anti-skid pads on the bottom and can rest on any desired horizontal surface or countertop. The scanner (along with the stand/riser) can be easily repositioned on the counter or lifted for portable use.

### Removing the Stand/Bottom Cover



**CAUTION**

**Do not attempt to remove the Stand without first unplugging the Cable as described. Doing so may result in damage to the scanner.**

1. Unplug the Power Interface Cable by inserting a paper clip or similar object into the latch release hole as shown in [Figure 2 on page 2](#).
2. After removing the Interface Cable, pull the bottom of the Stand forward (in the direction of the Front Window) to detach it from the unit. It will snap free easily if oriented correctly.

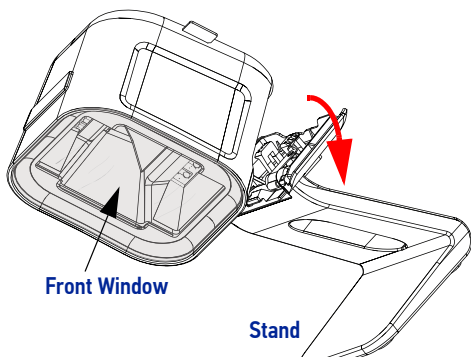

## Magnetic Base Mounting

The magnetic swivel base can be used to semi-permanently attach a scanner to a flat surface (vertical or horizontal), using the provided adhesive or screw. Both the stand and riser options mount onto the



magnetic swivel base and are held magnetically in place. The scanner can easily be rotated to a desired orientation. The scanner (along with the riser or stand) can be detached for portable use by lifting the entire unit as shown in [Figure 4 on page 5](#).

## HOW TO SCAN

Bar codes can be presented to the scanner while it is resting on the counter or in the optional stand, or the scanner can be picked up for targeted scanning.

**Figure 4. Scanning Methods**

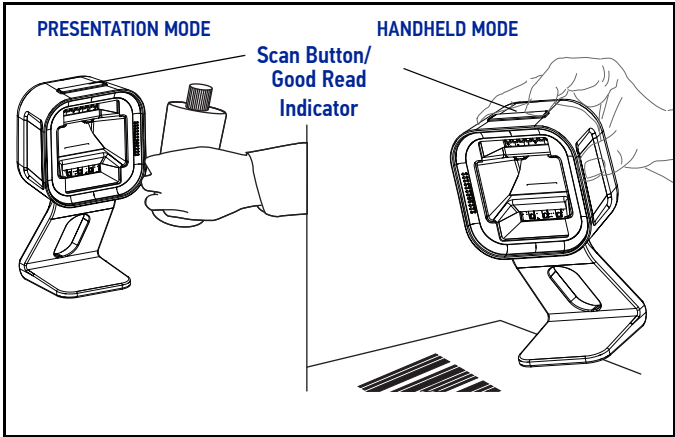

### Handheld Scanning Mode

To read a barcode using Handheld Scanning Mode:

1. Pick up the scanner- the aimer LED will illuminate automatically.
2. With the aimer over the barcode to be read, press and release the button.

Upon a successful read, the button will blink bright green and the green spot will illuminate, highlighting the decoded barcode.

---

## Center Zone Qualification

The configurable Center Zone can be set to limit the scan area to allow Targeted Scanning of pick lists or other special items. Bar codes will read in any orientation. The scanner will return to full pattern Presentation Mode when set back down, after a configurable time has elapsed.

## Scanner Button

The Scanner Button performs multiple functions, depending on how long it is pressed:

### Scanner Button Functions



#### NOTE

**The Scanner Button functions shown below are operational only when the Scanner is stationary. When in Hand/Portable mode, the button acts as a trigger to enable the reading of a barcode label.**

PRESS DURATION	FUNCTION	COMMENT
Momentary (when scanner is asleep)	Wakes scanner from Sleep Mode	Alternatively, the scanner can be awakened by moving an object through the scan zone.
Momentary (when scanner is awake)	Increments volume	Press the button momentarily to increase speaker volume. When the loudest volume is reached, a repeated press of the button cycles volume back to the lowest setting, then volume increases on subsequent press(es). Five volume levels are available.
Hold, then release when the beeper sounds	Increments tone	Press the button for approximately 2 seconds, then release. Each time this is done, the beeper will sound at one of three tones. Stop when the desired tone (high, medium or low) is sounded.

PRESS DURATION	FUNCTION	COMMENT
4 Seconds	Scanner Diagnostics Mode <sup>a</sup>	This mode allows system support personnel to troubleshoot problems with the scanner and is used to determine if it can read bar codes. Press the button for 8 seconds or cycle power to exit Scanner Diagnostics Mode and reset the scanner.
10 Seconds	Resets Scanner <sup>b</sup>	Only system support personnel should perform a reset.
<p>a. By standard default, this function is normally disabled to prevent accidental activation by users.</p> <p>b. Users should not perform scanner resets except under the direction of trained systems support personnel.</p>		



**Volume changes made using the Scanner Button are lost when the scanner is powered down and are reset to the configured setting. If you wish to permanently change the volume, use the special programming labels in the Product Reference Guide.**

## LED AND BEEPER INDICATORS

The scanner's beeper sounds and its green LED illuminates to indicate various functions or errors on the scanner. The tables that follow list these indications. An exception is that the scanner's functions are programmable, and may or may not be turned on. For example, some indications (such as the power-up beep) can be disabled using programming bar code labels.

LED INDICATION	INDICATION	COMMENT
Power-on indication	Bright green flash	Indicates the scanner has finished all its power-up tests and is now ready for operation.
Good Read Indication	Bright green flash	Indicates a bar code has been read and decoded.
Scanner Ready	Constant dim green	The scanner is ready for operation.
Sleep Mode	Green LED slowly and continuously changes from off to dim to off.	The scanner is in Sleep Mode. To wake the scanner up, move an object in front of its window or press the button atop the unit. This indication is optionally configurable, and may have been programmed to behave differently.
Host Disable	Constant green flash at 1 Hz (100mS on, 900mS off)	The scanner is disabled due to receiving a disable command from the POS terminal.
Diagnostics	Varies (see " <a href="#">Error Codes</a> " on page 16 for more information)	The LED can provide diagnostic feedback if the scanner discovers a problem during SelfTest.
Prog. Mode	Constant green flash at 1 Hz (500 ms on, 500 ms off).	The scanner is in Programming Mode.

BEEPER INDICATION	INDICATION	COMMENT
Power On Beep	Single beep	The Power-On LED indication is a configurable feature which can be enabled or disabled. When enabled, this beep indicates the scanner has finished all its power-up tests and is now ready for operation.
Good Read Indication	Single beep	The good read beep indication is configurable. Options include: Enable/disable, frequency, duration and volume. See the Product Reference Guide (PRG) for more information.
Diagnostics	Varies (see <a href="#">"Error Codes" on page 16</a> for more information)	The Beeper can provide diagnostic feedback if the scanner discovers a problem during SelfTest.
Programming Mode Indications	Varies depending upon the feature(s) being configured.	The Beeper will sound as programming bar code labels are scanned, indicating progress during scanner configuration.

---

## PROGRAMMING

On leaving the factory, units are generally programmed with the most common terminal and communications settings. If you need to change these settings, custom programming can be accomplished using one of several methods.

This manual offers programming barcodes for common functions. Additional programming barcodes are available in the PRG, or use software utilities which are available on the Wasp website.

### Service Port Mode

To program the WPS1500 using Scanalyzer or Aladdin, the unit must first be placed into Service Port mode, as follows:

1. Unplug the unit if needed.
2. While Holding down the Scan Button on the top of the unit, plug the scanner in.
3. The scanner will enter Service Port Mode, enabling it to be programmed via software utilities.

### Using Barcodes



**It is not necessary to place the scanner into Service Port Mode to program with barcode labels.**

#### NOTE

After completing the physical connection between the scanner and its host, go to the Programming Bar Codes table on the following pages to locate the interface type for your scanner (such as RS-232, USB, etc.).

Scan a START/END bar code once to enter Programming Mode. After scanning the programming label for the desired interface, scan the START/END barcode a second time to accept your changes, exit Programming Mode and return the scanner to normal operation.

## Interface Selection



START / END

### PROGRAMMING BAR CODES



RS-232 Standard



RS-232 Wincor-Nixdorf



USB-OEM



USB Keyboard



USB COM Interface



#### NOTE

Reference the Product Reference Guide (PRG) or configuration software for additional options. All are available for download on the Wasp website at no charge.

---

## Good Read Green Spot Duration

Successful reading can be signaled by a good read green spot. Use the bar codes that follow to specify the duration of the good read pointer beam after a good read.



START / END



Disabled



◆ Short (300 ms)



Medium (500 ms)



Long (800 ms)



---

## Cell Phone Mode

Enables/disables mobile phone barcode reading.

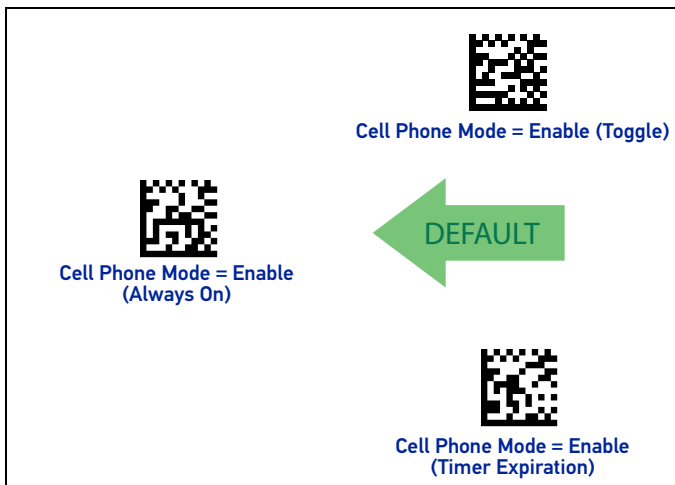

## Cell Mode Frequency

Specifies the frequency when reading cell phones. Cell phone mode must be enabled for this feature to be active.



**Higher Settings will slow down read performance on printed barcodes.**

### NOTE

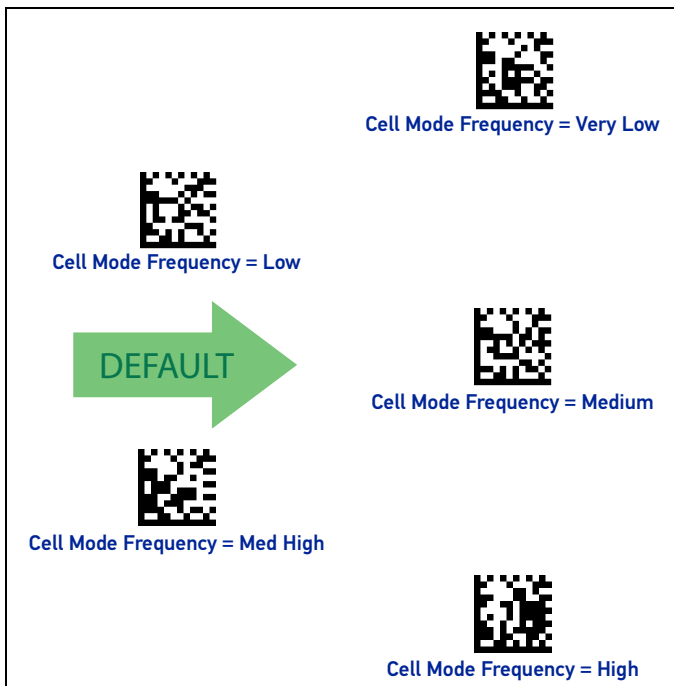

## TROUBLESHOOTING

If the scanner is not operating properly, the following checks should be performed:

PROBLEM	SOLUTION
Scanner does not power on	Exchange the power supply with a known good power supply and retest operation.
	<p>If an RS-232 cable is used on a scanner configured for USB, powerup will not occur because the scanner will be waiting for enumeration from the host.</p> <p>As a workaround, hold the scanner's button down, then apply power. Release the button when the green light comes on. The scanner will power up with limited scanning, which will allow you to scan programming labels to reconfigure the scanner to the desired interface.</p>
No communication with the host	Verify the interface cable is securely attached to the host and the scanner. Consult your technical support personnel or refer to your host system manual to verify the proper interface type, cable and connection port(s) for the scanner.
The scanner will not read bar codes at all, or reads poorly	<p>Check that the bar codes are of sufficient quality to be recognized by the scanner. Wrinkled, smudged, or torn labels can cause the scanner to not read at all. Scan known-good labels of an active symbology<sup>a</sup> to check the scanner's read operation.</p> <p>Make sure the window is clean.</p>
<p>a. Reading of the various bar code symbologies can be independently enabled or disabled in the scanner.</p>	

If the scanner still does not function properly, consult the Product Reference Guide (PRG) or contact your local supplier or Wasp Customer Support Services.

---

## Error Codes

If an error is detected, the scanner will sound a long low tone (for three seconds) and flash its LED, indicating a failure. When this occurs, press the Scanner button to hear the error code. If it is configured to do so, the scanner will sound a series of beeps corresponding to the error code and/or flash its LED simultaneous to the beeps. The table below describes what these codes mean and what action should be taken for each.

NUMBER OF LED FLASHES/ BEEPS	ERROR	CORRECTIVE ACTION
1	Configuration	<b>Contact Helpdesk for assistance</b>
2	Host Interface	
6	Main PCB	
10	Button Error	
11	USB Device	
13	FPGA ID	

## CLEANING

Exterior surfaces and scan windows exposed to spills, smudges or debris accumulation require periodic cleaning to assure best performance during scanning. Use a clean, lint-free cloth or paper towel dampened with a nonabrasive, mild, water-based cleaner to wipe away stains, smudges, fingerprints, spills, etc. from the scan window and exterior surfaces.

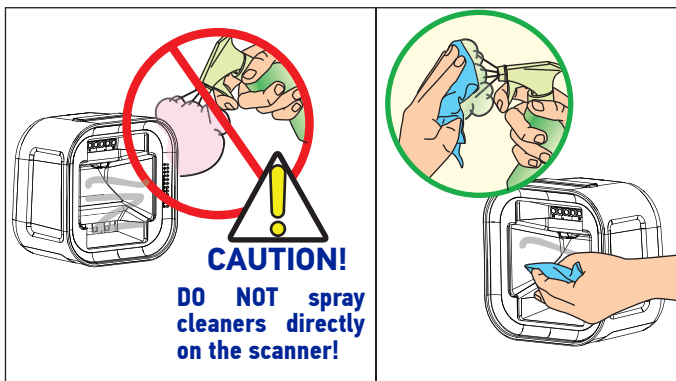

**DO NOT use abrasive cleaning agents or abrasive pads to clean this product. Harsh chemicals, disinfectants, and cleansers can cause damage which will adversely affect scanning performance.**

See the next page for a list of [Manufacturer Approved Cleaning Materials](#).

---

## Manufacturer Approved Cleaning Materials

Wasp recommends the use of the following cleaners on its products.



### APPROVED CLEANERS

- Hydrogen Peroxide (not to exceed a 3% solution)
- Chlorine bleach (not to exceed a 0.25% solution)
- Mild detergent and water
- Isopropyl Alcohol (not to exceed a 70% solution)



**CAUTION**

**Use of above cleaners *in combination with each other* is not recommended and may constitute a health hazard. Follow all specified safety precautions when using any cleaning solution.**

Under no circumstances should abrasive cleansers, abrasive pads, caustic solutions or other harsh chemicals, including those listed below, be used on any part of the scanner as they can cause damage which will adversely affect scanning performance. Use of such materials, either alone or in combination with other cleaning agents, will void the manufacturer's warranty.



### !!DO NOT USE!!

- Ammonia solutions
- Acetone
- Benzene
- Ethanolamine
- Ethers
- Ketones
- Trichloroethylene
- Toluene
- Carboic acid
- Aromatic or chlorinated hydrocarbons
- Aqueous or alcoholic alkaline solutions

---

# WARRANTY

Wasp warrants to Customer that this product will be free from defects in materials and workmanship for a period of 3 years from product shipment.

Wasp warrants that the goods delivered under these General Terms for the Sale of Goods shall be free from defects in materials and workmanship under normal and proper use during the Warranty Period (as defined below). Wasp's liability under this warranty is limited to furnishing the labor and parts necessary to remedy any defect covered by this warranty and restore the product to its normal operating condition. Repair or replacement of product during the warranty does not extend the original warranty term. Products are sold on the basis of specifications applicable at the time of manufacture and Wasp has no obligation to modify or update products once sold. The warranty period shall extend from the date of shipment from Wasp for the duration published by Wasp for the product at the time of purchase ("Warranty Period").

If, during the Warranty Period, Wasp determines that a product has defects in material or workmanship, Wasp shall, at its sole option repair or replace the product without additional charge for parts and labor, or give a credit for the defective products duly returned to Wasp. To perform repairs, Wasp may use new or reconditioned parts, components, subassemblies or products that have been tested as meeting applicable specifications for equivalent new material and products. Buyer will allow Wasp to scrap all parts removed from the repaired product. Wasp warrants repaired hardware devices only, against defects in workmanship and materials on the repaired assembly for a 90 day period starting from the date of shipment of the repaired product from Wasp or until the expiration of the original Warranty Period, whichever is longer. Wasp does not guarantee, and it is not responsible for, the maintenance of, damage to, or loss of configurations, data, and applications on the repaired units and at its sole discretion can return the units in the "factory default" configuration or with any software or firmware update available at the time of the repair (may be newer than the firmware or software installed during the manufacture of the product). Buyer accepts responsibility to maintain a backup copy of its software and data.

## Warranty Exclusions

The Wasp Warranty shall not apply to:

- (i) any product which has been damaged, modified, altered, repaired or upgraded by other than Wasp service personnel or its authorized representatives;
- (ii) defects or damages caused by any third parties' tort committed against the Buyer.
- (iii) any claimed defect, failure or damage which Wasp determines was caused by faulty operations, improper use, abuse, misuse, wear and tear, negligence, improper storage or use of parts or accessories not approved or supplied by Wasp;
- (iv) any claimed defect or damage caused by the use of product with any other instrument, equipment or apparatus;
- (v) any claimed defect or damage caused by the failure to provide proper maintenance, including but not limited to cleaning the upper window in accordance with product manual or the replacement of upper window/cartridge due to scratching, stain or other degradation;
- (vi) any defect or damage caused by natural or man-made disaster such as but not limited to fire, water damage, floods, other natural disasters, vandalism or abusive events that would cause internal and external component damage or destruction of the whole unit, consumable items;
- (vii) any damage or malfunctioning caused by non-restoring action as for example firmware or software upgrades, software or hardware reconfigurations etc.;
- (viii) any consumable or equivalent (e.g. cables, power supply, batteries, etc.).

---

Consumable items, such as batteries and cables, carry a 90 day warranty from time of purchase for DOA (dead on arrival) defects alone.

Wasp specifically excludes all express warranties and makes no implied warranty that the products sold under this agreement are merchantable or are fit for any particular purpose, except such warranties expressly identified as warranties as are set forth in Wasp's current operating manual, catalog, or written guarantee covering such product.

No affirmation of fact or promise made by Wasp, whether in this contract or communicated otherwise, shall constitute a warranty that the goods will conform to the affirmation or promise.

## Warranty Claim Process

In order to obtain service under this Warranty, Buyer must notify Wasp (which notice shall be in writing sent by registered courier or mail) of the claimed defect before the expiration of the Warranty period and obtain from Wasp a return authorization number for return of the product to designated Wasp service center. Buyer shall offer Wasp the opportunity to investigate the claim and to inspect the allegedly defective products. Failure to offer Wasp such opportunity shall constitute acceptance by Buyer and waiver of all claims for defects. The products must always be returned within ten (10) days from the date of authorization issued by Wasp. If Wasp determines Buyer's claim is valid, Wasp will repair or replace product without additional charge for parts and labor. Buyer shall be responsible for packaging and shipping the product to the designated Wasp service center, with shipping charges prepaid. Wasp shall pay for the return of the product to Buyer if the shipment is to a location within the country in which the Wasp service center is located. Buyer shall be responsible for paying all shipping charges, duties, taxes, and any other charges for products returned to any other locations.

WASP'S WARRANTY, AS DESCRIBED HEREIN, IS IN LIEU OF ALL OTHER WARRANTIES, EXPRESS OR IMPLIED, ORAL OR WRITTEN, STATUTORY OR OTHERWISE, INCLUDING, WITHOUT LIMITATION, ANY IMPLIED WARRANTIES OF MERCHANTABILITY, FITNESS FOR A PARTICULAR PURPOSE, OR NONINFRINGEMENT. WASP SHALL NOT BE LIABLE FOR ANY DAMAGES SUSTAINED BY BUYER ARISING FROM DELAYS IN THE REPLACEMENT OR REPAIR OF PRODUCTS UNDER THE ABOVE. THE REMEDY SET FORTH IN THIS WARRANTY STATEMENT IS THE BUYER'S SOLE AND EXCLUSIVE REMEDY FOR WARRANTY CLAIMS. UNDER NO CIRCUMSTANCES WILL WASP BE LIABLE TO BUYER OR ANY THIRD PARTY FOR ANY LOST PROFITS, OR ANY INCIDENTAL, CONSEQUENTIAL INDIRECT, SPECIAL OR CONTINGENT DAMAGES REGARDLESS OF WHETHER WASP HAD ADVANCE NOTICE OF THE POSSIBILITY OF SUCH DAMAGES. WASP'S LIABILITY FOR DAMAGES ON ACCOUNT OF A CLAIMED DEFECT IN ANY PRODUCT DELIVERED BY WASP SHALL IN NO EVENT EXCEED THE PURCHASE PRICE OF THE PRODUCT ON WHICH THE CLAIM IS BASED. WASP SHALL NOT BE LIABLE FOR DAMAGES RELATING TO ANY INSTRUMENT, EQUIPMENT, OR APPARATUS WITH WHICH THE PRODUCT SOLD UNDER THIS AGREEMENT IS USED.

## Out of Warranty Services

For products no longer covered by warranty services, Wasp may offer billable repair services on products, provided such products are serviceable. Buyer acknowledges and accepts that for some older products the repair may exceed the costs of manufacturing a new product and Wasp may decline to perform repair services. Upon Buyer's request for out of warranty services, Wasp will evaluate the request of repair and shall provide, to the extent applicable and feasible according to the above, a cost-estimate for repairs, which will be on a time and materials basis.



---

## Remedies

If Buyer fails, with or without cause, to furnish Wasp with specifications and/or instructions for, or refuses to accept deliveries of, any of the products sold under this contract, or is otherwise in default under or in repudiation of this contract or any other contract with Wasp or fails to pay when due any invoice under this contract, then in addition to any and all remedies allowed by law, Wasp without notice may (1) bill and declare due and payable all undelivered products under this or any other contract between Wasp and the Buyer; and/or (2) defer shipment under this or any other contract between the Buyer and Wasp until such default, breach, or repudiation is removed; and/or (3) may cancel any undelivered portion of this and/or any other contract in whole or in part (with Buyer remaining liable for damages).

## Risk of Loss

Buyer shall bear risk of loss or damage for product in transit to Wasp. Wasp shall assume risk of loss or damage for product in Wasp's possession. In the absence of specific written instructions for the return of product to Buyer, Wasp will select the carrier, but Wasp shall not thereby assume any liability in connection with the return shipment.

---

# NOTES



©2020 Wasp Barcode Technologies and/or its affiliates

• All rights reserved • Without limiting the rights under copyright, no part of this documentation may be reproduced, stored in or introduced into a retrieval system, or transmitted in any form or by any means, or for any purpose, without the express written permission of Wasp and/or its affiliates • Wasp Barcode Technologies and the Wasp logo are registered trademarks of Wasp in many countries, including the U.S. and the E.U.

# Wasp

**BARCODE TECHNOLOGIES**

[www.waspbarcode.com](http://www.waspbarcode.com)

**Wasp Barcode Technologies**

1400 10th St.  
Plano, TX 75024  
866-547-9277

**Revised 8.2020**