

**WPL308 Series**

**THERMAL TRANSFER / DIRECT THERMAL  
BAR CODE PRINTER**

**USER'S  
MANUAL**

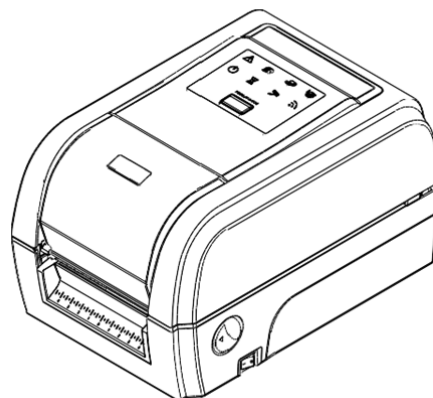

## **Copyright Information**

©2014 Wasp Barcode Technologies.

The copyright in this manual, the software and firmware in the printer described therein are owned by Wasp Barcode Technologies, All rights reserved.







CG Triumvirate is a trademark of Agfa Corporation. CG Triumvirate Bold Condensed font is under license from the Monotype Corporation. Windows is a registered trademark of Microsoft Corporation.

All other trademarks are the property of their respective owners.

Information in this document is subject to change without notice and does not represent a commitment on the part of Wasp Barcode Technologies. No part of this manual may be reproduced or transmitted in any form or by any means, for any purpose other than the purchaser's personal use, without the expressed written permission of Wasp Barcode Technologies.

## Agency Compliance and Approvals

---

	EN 55022, Class B EN 55024 EN 60950-1
	FCC part 15B, Class B
	AS/NZS CISPR 22, Class B
	UL 60950-1
	EN 60950-1
	GB 4943.1 GB 9254 GB 17625.1

---

### Wichtige Sicherheits-Hinweise

1. Bitte lesen Sie diese Hinweis sorgfältig durch.
2. Heben Sie diese Anleitung für den späteren Gebrauch auf.
3. Vor jedem Reinigen ist das Gerät vom Stromnetz zu trennen. Verwenden Sie keine Flüssig-oder Aerosolreiniger. Am besten eignet sich ein angefeuchtetes Tuch zur Reinigung.
4. Die Netzanschluß-Steckdose soll nahe dem Gerät angebracht und leicht zugänglich sein.
5. Das Gerät ist vor Feuchtigkeit zu schützen.
6. Bei der Aufstellung des Gerätes ist auf sicheren Stand zu achten. Ein Kippen oder Fallen könnte Beschädigungen hervorrufen.
7. Beachten Sie beim Anschluß ans Stromnetz die Anschlußwerte.
8. Dieses Gerät kann bis zu einer Außentemperatur von maximal 40°C betrieben werden.

### Battery safety warning:

- DO NOT throw the battery in fire.
- DO NOT short circuit the contacts.
- DO NOT disassemble the battery.

DO NOT throw the battery in municipal waste.

The symbol of the crossed out wheeled bin indicates that the battery should not be placed in municipal waste.

### **CAUTION**

Risk of explosion if battery is replaced by an incorrect type.

Dispose of used batteries according to the instructions.

### **“VORSICHT”**

Explosionsgefahr bei unsachgemäßen Austausch der Batterie. Ersatz nur durch denselben oder einem vom Hersteller empfohlenem ähnlichen Typ. Entsorgung gebrauchter Batterien nach Angaben des Herstellers.

### **FCC STATEMENT :**

This equipment has been tested and found to comply with the limits for a Class B digital device, pursuant to part 15 of the FCC Rules. These limits are designed to provide reasonable protection against harmful interference in a residential installation. This equipment generates, uses and can radiate radio frequency energy and, if not installed and used in accordance with the instructions, may cause harmful interference to radio communications. However, there is no guarantee that interference will not occur in a particular installation. If this equipment does cause harmful interference to radio or television reception, which can be determined by turning the equipment off and on, the user is encouraged to try to correct the interference by one or more of the following measures:

- Reorient or relocate the receiving antenna.
- Increase the separation between the equipment and receiver.
- Connect the equipment into an outlet on a circuit different from that to which the receiver is connected.
- Consult the dealer or an experienced radio/ TV technician for help.

This device complies with Part 15 of the FCC Rules. Operation is subject to the following two conditions: (1) This device may cause harmful interference, and (2) this device must accept any interference received, including interference that may cause undesired operation.

**This Class B digital apparatus complies with Canadian ICES-003**  
**Cet appareil numérique de la classe B est conforme à la norme NMB-003 du Canada.**

### **CAUTION:**

Any changes or modifications not expressly approved by the grantee of this device could void the user's authority to operate the equipment.

**CAUTION :**

HAZARDOUS MOVING PARTS, KEEP FINGER AND OTHER BODY PARTS AWAY.

Equipment name :						
Type designation (Type) : WPL308						
Unit	Restricted substances and its chemical symbols					
	Lead (Pb)	Mercury (Hg)	Cadmium (Cd)	Hexavalent chromium	Polybrominated biphenyls	Polybrominated diphenyl ethers (PBDE)
	○	○	○	○	○	○
	—	○	○	○	○	○
	○	○	○	○	○	○
	○	○	○	○	○	○
	○	○	○	○	○	○
	—	○	○	○	○	○
	—	○	○	○	○	○
	○	○	○	○	○	○
	—	○	○	○	○	○
	○	○	○	○	○	○
	○	○	○	○	○	○
	—	○	○	○	○	○
	—	○	○	○	○	○
	—	○	○	○	○	○
	—	○	○	○	○	○
	—	○	○	○	○	○
	—	○	○	○	○	○
	—	○	○	○	○	○
	—	○	○	○	○	○
<p>1. "0.1 wt %" "0.01 wt %"</p> <p>Note 1 : "Exceeding 0.1 wt %" and "exceeding 0.01 wt %" indicate that the percentage content of the restricted substance exceeds the reference percentage value of presence condition.</p> <p>2. "○"</p> <p>Note 2 : "○" indicates that the percentage content of the restricted substance does not exceed the percentage of reference value of presence.</p> <p>3. "—"</p> <p>Note 3 : The "—" indicates that the restricted substance corresponds to the exemption.</p>						

# Contents

1. Introduction.....	1
1.1 Product Introduction .....	1
1.2 Product Features.....	2
<b>1.2.1 Printer Standard Features</b> .....	2
<b>1.2.2 Printer Optional Features</b> .....	4
1.3 General Specifications .....	5
1.4 Print Specifications .....	5
1.5 Ribbon Specifications.....	5
1.6 Media Specifications .....	6
2. Operations Overview.....	7
2.1 Unpacking and Inspection.....	7
2.2 Printer Overview.....	8
<b>2.2.1 Front View</b> .....	8
<b>2.2.2 Interior view</b> .....	9
<b>2.2.3 Rear View</b> .....	10
2.3 Operator Control.....	11
<b>2.3.1 LED Indication and Key</b> .....	11
3. Setup .....	12
3.1 Setting up the printer .....	12
3.2 Loading the Ribbon .....	13
3.3 Loading the Media.....	16
<b>3.3.1 Loading the Media</b> .....	16
<b>3.3.2 Loading Media in Cutter Mode (Option)</b> .....	19
<b>3.3.3 Loading Media in Peel-off Mode (Option)</b> .....	20
4. Diagnostic Tool.....	22
4.1 Start the Diagnostic Tool.....	22
4.2 Printer Function .....	23
4.3 Setting Ethernet by Diagnostic Tool.....	24
<b>4.3.1 Using USB interface to setup Ethernet interface</b> .....	24
<b>4.3.2 Using RS-232 interface to setup Ethernet interface</b> .....	24

<b>4.3.3 Using Ethernet interface to setup Ethernet interface</b> .....	26
5. Power-on Utilities .....	28
5.1 Ribbon and Gap/Black Mark Sensor Calibration .....	29
5.2 Gap/Black Mark Calibration, Self-test and Dump Mode .....	30
5.3 Printer Initialization .....	34
5.4 Set Black Mark Sensor as Media Sensor and Calibrate the Black Mark Sensor 36	
5.5 Set Gap Sensor as Media Sensor and Calibrate the Gap Sensor.....	37
5.6 Skip AUTO.BAS .....	38
6. LCD Menu Function .....	39
6.1 Enter the Menu .....	39
6.2 Main Menu Overview.....	40
6.3 WPL2.....	41
6.4 ZPL2.....	43
6.5 Sensor.....	46
6.6 Interface .....	47
<b>6.6.1 Serial Comm</b> .....	47
<b>6.6.2 Ethernet</b> .....	48
<b>6.6.3 Bluetooth</b> .....	49
<b>6.6.4 Wi-Fi</b> .....	49
6.7 File Manager .....	50
6.8 Diagnostics .....	51
<b>6.8.1 Print Config</b> .....	51
<b>6.8.2 Dump Mode</b> .....	53
<b>6.8.3 Print Head</b> .....	54
<b>6.8.4 Display</b> .....	54
<b>6.8.5 Sensor</b> .....	54
6.9 Advanced .....	55
6.10 Service .....	56
7. Troubleshooting.....	57
8. Maintenance .....	60
Revise History.....	61

# 1. Introduction

---

## 1.1 Product Introduction

Thank you very much for purchasing a Wasp Barcode printer.

The WPL308 series of thermal transfer desktop barcode printers supports more printing applications than any other printer in its class. With three models available, the four inch wide WPL308 series can address everything from higher volume 4x6 shipping labels, higher resolution product marking and graphic solutions, to high resolution labels used in electronics marking applications.

The printers use a large 300 meter ribbon supply on a one inch core that saves both time and money. The WPL308 series features a user-friendly spring-loaded center-biased clamshell design for easy drop-in media loading of 5-inch rolls of media. The printer construction features a rugged double-wall design that is stronger and more durable than other thermal transfer mechanisms on the market. Its strong motor is powerful enough to handle a 300-meter-long ribbon.

As with all Wasp Barcode printers, the WPL308 Series features the WPL-EZ™ printer-control language, which is fully compatible with other Wasp Barcode printer languages, while supporting TPLE (Translation Printer Language Eltron®) and TPLZ (Translation Printer Language Zebra®). The languages automatically decipher and translate the format of each label as it is sent to the printer. WPL-EZ™ also features internal scalable True Type fonts (based on the Monotype® font engine), which are typically found only in more expensive printers. Applications:

- Business/Office
- Product Marking
- Compliance Labeling
- Asset Tracking
- Document Management
- Shelf-Labeling
- Shipping/Receiving
- Specimen Labeling
- Inventory Control
- Patient Tracking



## 1.2 Product Features

### 1.2.1 Printer Standard Features

The printer offers the following standard features.

Product standard feature	200 dpi model	300 dpi model	600 dpi model
Thermal transfer/ or direct thermal	○	○	○
LED icon panel with 1 button	○	○	-
3.5" TFT LCD with 6 buttons	-	-	○
32-bit RISC high performance processor	○	○	○
Gap transmissive sensor (Fixed, center of offset 4 to right or 7 mm to left from center)	○	○	○
Black mark reflective sensor (Position adjustable)	○	○	○
See-through ribbon end sensor	-	-	○
Ribbon encoder sensor <i>For single printing, the label length should be more than 3 mm. 39.4mm is the threshold of ribbon low detection. The ribbon LED becomes blinking if ribbon supply roll diameter is less than 39.4 mm.</i>	○	○	○
Head open sensor	○	○	○
128MB Flash memory	○	○	○
128 MB DDR2 DRAM	○	○	○
Micro SD card reader for memory expansion, up to SDHC 32GB	○	○	○
RS-232 interface (Max. 115,200 bps)	○	○	○
USB 2.0 interface (Hi-speed mode)	○	○	○
Internal Ethernet print server (10/100 Mbps) interface	-	-	○
USB host	○	○	○
Real time clock & Buzzer	-	-	○
Standard industry emulations right out of the box including Eltron <sup>®</sup> and Zebra <sup>®</sup> language support	○	○	○
Internal 8 alpha-numeric bitmap fonts	○	○	○
Fonts and bar codes can be printed in any one of the four directions (0, 90, 180, 270 degree)	○	○	○
Internal Monotype Imaging <sup>®</sup> true type font engine with one CG Triumvirate Bold Condensed scalable font	○	○	○
Downloadable fonts from PC to printer memory	○	○	○
Clean print head warning	○	○	○

Bar code, graphics/image printing												
<table border="1"> <thead> <tr> <th colspan="2">Supported bar code</th> <th>Supported image</th> </tr> </thead> <tbody> <tr> <td>1D bar code</td> <td>2D bar code</td> <td rowspan="2">BITMAP, BMP, PCX (Max. 256 colors graphics)</td> </tr> <tr> <td>Code128 subsets A.B.C, Code128UCC, EAN128, Interleave 2 of 5, Code 39, Code 93, EAN-13, EAN-8, Codabar, POSTNET, UPC-A, UPC-E, EAN and UPC 2(5) digits, MSI, PLESSEY, China Post, ITF14, EAN14, Code 11, TELPEN, PLANET, Code 49, Deutsche Post Identcode, Deutsche Post Leitcode, LOGMARS</td> <td>CODABLOCK F mode, DataMatrix, Maxicode, PDF-417, Aztec, MicroPDF417, QR code, RSS Barcode (GS1 Databar)</td> </tr> </tbody> </table>		Supported bar code		Supported image	1D bar code	2D bar code	BITMAP, BMP, PCX (Max. 256 colors graphics)	Code128 subsets A.B.C, Code128UCC, EAN128, Interleave 2 of 5, Code 39, Code 93, EAN-13, EAN-8, Codabar, POSTNET, UPC-A, UPC-E, EAN and UPC 2(5) digits, MSI, PLESSEY, China Post, ITF14, EAN14, Code 11, TELPEN, PLANET, Code 49, Deutsche Post Identcode, Deutsche Post Leitcode, LOGMARS	CODABLOCK F mode, DataMatrix, Maxicode, PDF-417, Aztec, MicroPDF417, QR code, RSS Barcode (GS1 Databar)	○	○	○
Supported bar code		Supported image										
1D bar code	2D bar code	BITMAP, BMP, PCX (Max. 256 colors graphics)										
Code128 subsets A.B.C, Code128UCC, EAN128, Interleave 2 of 5, Code 39, Code 93, EAN-13, EAN-8, Codabar, POSTNET, UPC-A, UPC-E, EAN and UPC 2(5) digits, MSI, PLESSEY, China Post, ITF14, EAN14, Code 11, TELPEN, PLANET, Code 49, Deutsche Post Identcode, Deutsche Post Leitcode, LOGMARS	CODABLOCK F mode, DataMatrix, Maxicode, PDF-417, Aztec, MicroPDF417, QR code, RSS Barcode (GS1 Databar)											
Supported code page:												
<ul style="list-style-type: none"> <li>• Codepage 437 (English - US)</li> <li>• Codepage 737 (Greek)</li> <li>• Codepage 850 (Latin-1)</li> <li>• Codepage 852 (Latin-2)</li> <li>• Codepage 855 (Cyrillic)</li> <li>• Codepage 857 (Turkish)</li> <li>• Codepage 860 (Portuguese)</li> <li>• Codepage 861 (Icelandic)</li> <li>• Codepage 862 (Hebrew)</li> <li>• Codepage 863 (French Canadian)</li> <li>• Codepage 864 (Arabic)</li> <li>• Codepage 865 (Nordic)</li> <li>• Codepage 866 (Russian)</li> <li>• Codepage 869 (Greek 2)</li> <li>• Codepage 950 (Traditional Chinese)</li> <li>• Codepage 936 (Simplified Chinese)</li> <li>• Codepage 932 (Japanese)</li> <li>• Codepage 949 (Korean)</li> <li>• Codepage 1250 (Latin-2)</li> <li>• Codepage 1251 (Cyrillic)</li> <li>• Codepage 1252 (Latin-1)</li> <li>• Codepage 1253 (Greek)</li> <li>• Codepage 1254 (Turkish)</li> <li>• Codepage 1255 (Hebrew)</li> <li>• Codepage 1256 (Arabic)</li> <li>• Codepage 1257 (Baltic)</li> <li>• Codepage 1258 (Vietnam)</li> <li>• ISO-8859-1: Latin-1 (Western European)</li> <li>• ISO-8859-2: Latin-2 (Central European)</li> <li>• ISO-8859-3: Latin-3 (South European)</li> <li>• ISO-8859-4: Latin-4 (North European)</li> <li>• ISO-8859-5: Cyrillic</li> <li>• ISO-8859-6: Arabic</li> <li>• ISO-8859-7: Greek</li> <li>• ISO-8859-8: Hebrew</li> </ul>		○	○	○								

<ul style="list-style-type: none"> <li>• ISO-8859-9: Turkish</li> <li>• ISO-8859-10: Nordic</li> <li>• ISO-8859-15: Latin-9</li> <li>• UTF-8</li> </ul>			
---	--	--	--

### 1.2.2 Printer Optional Features

The printer offers the following optional features.

Product option feature		User option	Dealer option	Factory option
Peel-off kit <i>Note: This peel-off module is supported for the thermal/ plain label only.</i>			○	
Regular cutter (full cut guillotine cutter) <b>Paper thickness: 0.06~ 0.19 mm</b> <i>Note: Except for the linerless cutter, all regular/heavy duty/care label cutters DO NOT cut on media with glue.</i>			○	
802.11 a/b/g/n wireless module (slot-in)			○	
KP-200 Plus keyboard display unit		○		
KU-007 Plus programmable smart keyboard		○		
Bluetooth module (serial interface)		○		
External label roll mount		○		
Parallel port				○
RFID				○
3.5" color TFT display	For 200 dpi and 300 dpi models			○
Real time clock				○
See-through ribbon end sensor				○

### 1.3 General Specifications

General Specifications	200 dpi model	300 dpi model	600 dpi
Physical dimensions	226 mm(W) x 198 mm(H) x 332 mm(D)		226 mm(W) x 200 mm(H) x 332 mm(D)
Weight	3.75 kg (8.27 lbs)		4.08 kg ( 8.99 lbs)
Mechanism	Clamshell with Double-walled plastic		
Power	External power adapter • Input: AC 100-240V/ 2.5A • Output: DC 24V/ 3.75A		External power adapter • Input: AC 100-240V, 2.5A • Output: DC 24V/ 5.41A
Environmental condition	Operation: 5 ~ 40 °C (41 ~ 104 °F), 25~85% non-condensing Storage: -40 ~ 60 °C (-40 ~ 140 °F), 10~90% non-condensing		
Environmental concern	Comply with RoHS, WEEE		

### 1.4 Print Specifications

Print Specifications	200 dpi model	300 dpi model	600 dpi model
Print head resolution (dots per inch/mm)	203 dots/inch (8 dots/mm)	300 dots/inch (12 dots/mm)	600 dots/inch (24 dots/mm)
Printing method	Thermal transfer/ or direct thermal		
Dot size (width x length)	0.125 x 0.125 mm (1 mm = 8 dots)	0.084 x 0.084 mm (1 mm = 12 dots)	0.042 x 0.042 mm (1 mm = 24 dots)
Print speed (inches per second)	Up to 8 IPS	Up to 6 IPS	Up to 4 IPS
	Max. 3 ips for peeler mode		
Max. print width	108 mm (4.25")	105.6 mm (4.15")	
Max. print length	25,400 mm (1000")	11,430 mm (450")	2,540 mm (100")
Printout bias	Vertical: 1 mm max. Horizontal: 1 mm max.		

### 1.5 Ribbon Specifications

Ribbon Specifications	
Ribbon outside diameter	Max. 67 mm OD
Ribbon length	300 meter
Ribbon core inside diameter	1" (25.4 mm) ID core
Ribbon width	40 mm ~ 110 mm
Ribbon wound type	Ink coated outside wound

### 1.6 Media Specifications

Media Specifications	200 dpi model	300 dpi model	600 dpi model
Media roll capacity	Max. 5" OD		
Media core diameter	1" & 1.5" ID core		
Media type	Continuous, die-cut, black mark, external fan-fold, notch		
Media wound type	Outside wound		
Media width	19 mm ~ 112 mm		
Media thickness	0.055 mm ~ 0.254 mm		
Label length	3 ~ 25,400 mm (0.1" ~ 1,000")	3 ~ 11,430 mm (0.1" ~ 450")	3 ~ 25,400 mm (0.1" ~ 1,000")
Label length (peeler mode)	25.4 mm ~ 152.4 mm (1" ~ 6")		
Label length (cutter mode)	25.4 ~ max. print length		
Black mark	Min. 8 mm (W) x 2 mm (H)		
Gap height	Min. 2 mm		

## 2. Operations Overview

---

### 2.1 Unpacking and Inspection

This printer has been specially packaged to withstand damage during shipping. Please carefully inspect the packaging and printer upon receiving the bar code printer. Please retain the packaging materials in case you need to reship the printer.

Unpacking the printer, the following items are included in the carton.

- One printer unit
- One Windows labeling software/Windows driver CD disk
- One quick installation guide
- One power cord
- One auto switching power supply
- One USB interface cable
- Two ribbon spindles
- One paper core

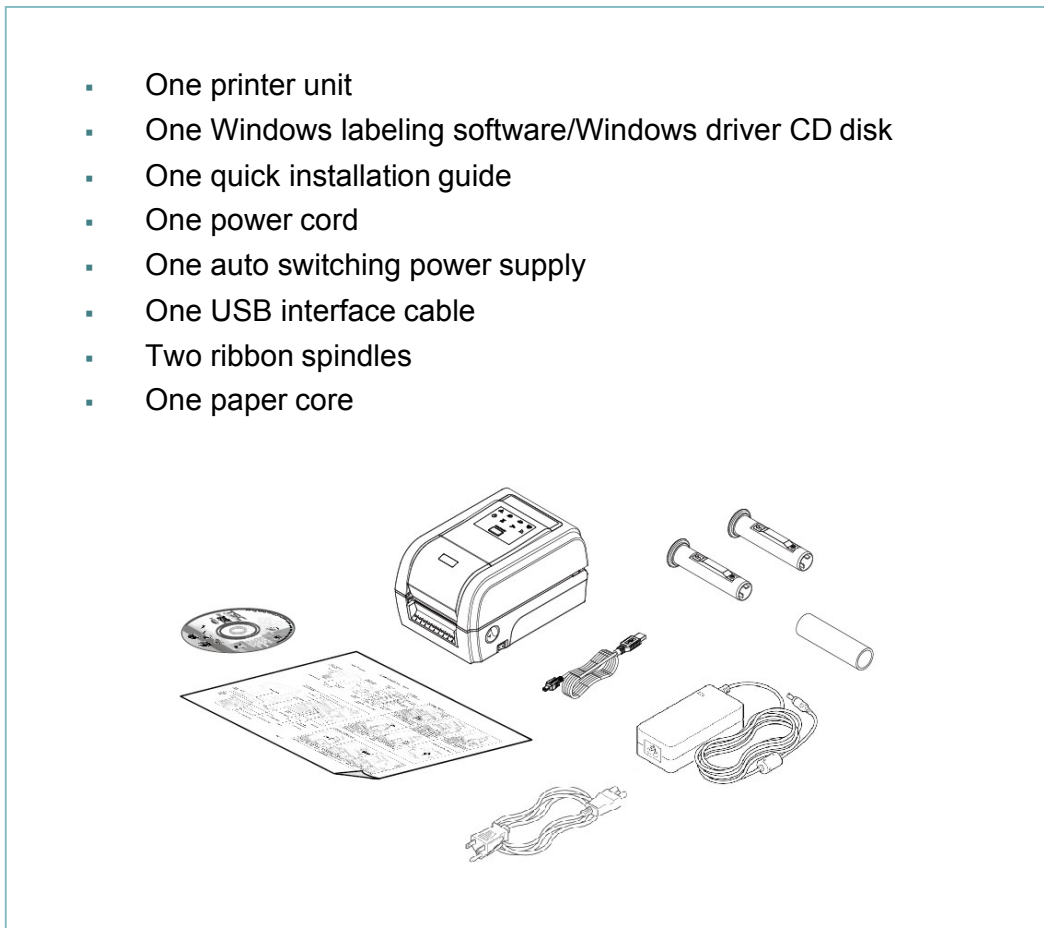

If any parts are missing, please contact the Customer Service Department of your purchased reseller or distributor.

## 2.2 Printer Overview

### 2.2.1 Front View



## 2.2.2 Interior view

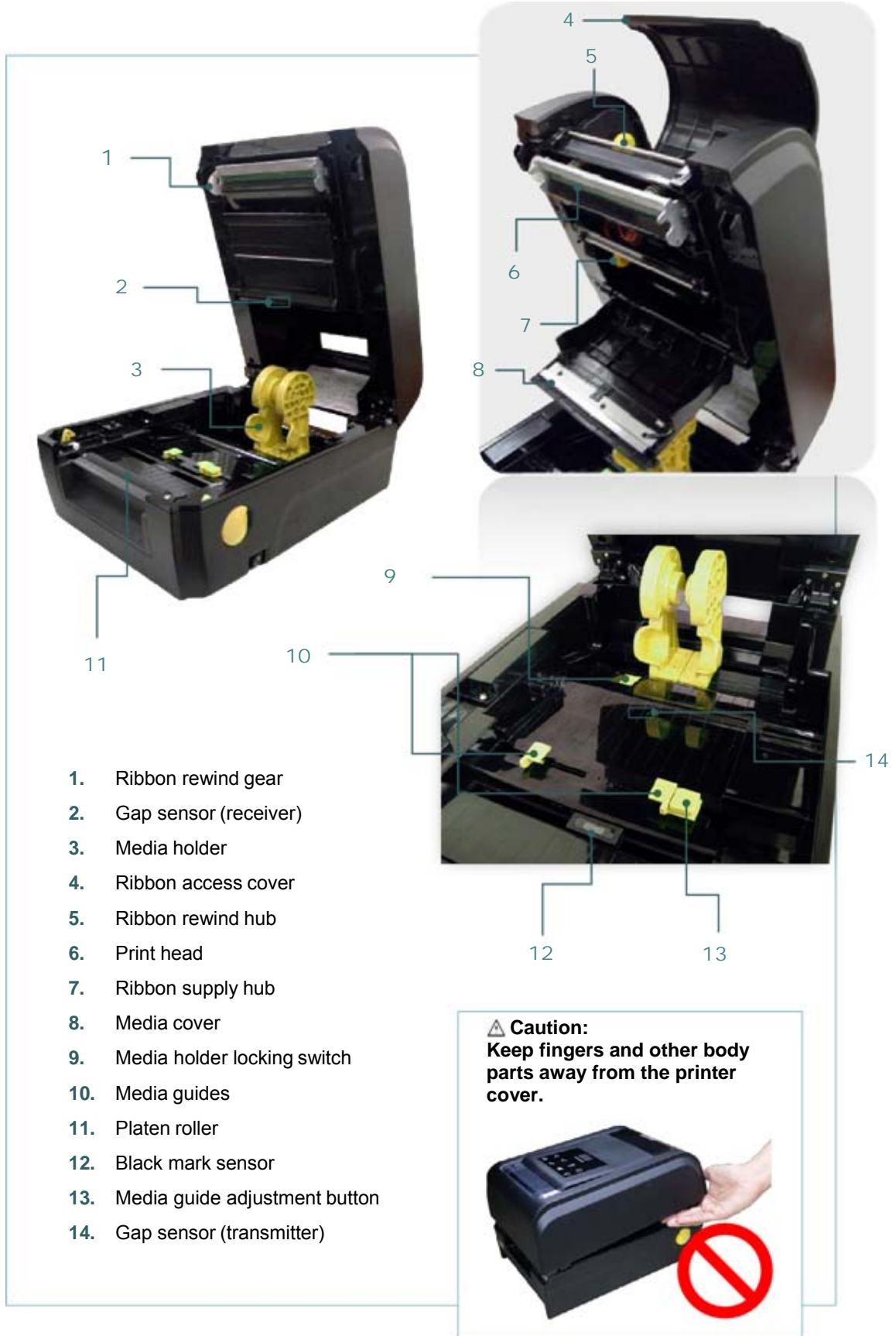



## 2.2.3 Rear View



**Note:**

\* Recommended MicroSD card specification.

Type	SD card spec	SD card capacity	Approved SD card manufacturer
Micro SD	V2.0 Class 4	4G	Transcend
	V2.0 Class 4	8G	Transcend
	V3.0 Class 10 UHS-I	16G	Transcend
	V3.0 Class 10 UHS-I	32G	Transcend
	V3.0 Class 10	16G	Kingston
	V2.0 Class 4	16G	Scandisk
	Class 10 UHS-I	16G	Scandisk

- The DOS FAT file system is supported for the SD card.
- Folders/files stored in the SD card should be in the 8.3 filename format

## 2.3 Operator Control

### 2.3.1 LED Indication and Key

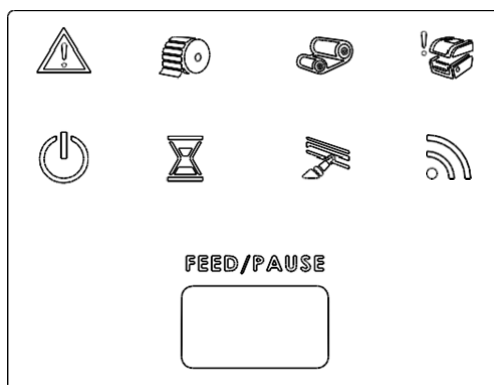

LED	Status	Indication
	On	Other errors
	On	Out of paper
	Blinking	Paper jam
	On	Out of ribbon
	Blinking	Ribbon near end
	On	Print head open

LED	Status	Indication
	On	Printer is ready
	Blinking	Pause
	On	Erasing memory
	Blinking	Downloading file
	Blinking	Need to clear print head
	Blinking	RF communication

#### (1) Feed labels

When the printer is ready, press the button to feed one label to the beginning of next label.

#### (2) Pause the printing job

When the printer is printing, press the button to pause a print job. When the printer is paused the power LED will blink green. Press the button again to continue the printing job.

## 3. Setup



---

### 3.1 Setting up the printer

1. Place the printer on a flat, secure surface.
2. Make sure the power switch is off.
3. Connect the printer to the computer with the provided USB cable.
4. Plug the power cord into the AC power cord socket at the rear of the printer, and then plug the power cord into a properly grounded power outlet.

**Note: Please switch OFF printer power switch prior to plug in the power cord to printer power jack.**

### 3.2 Loading the Ribbon

	<p>1. Open the printer's top cover by pulling the top cover open levers located on each side of the printer and lifting the top cover to the maximum open angle.</p>
	<p>2. Open the ribbon access cover and the media cover.</p>
	<p>3. Insert the rewind spindle into the paper core.</p>



**Note:**  
The yellow part of spindle is in left side.

4. Install the paper core right side onto the rewind hub first then align the notches on the left side and mount onto the spokes.



5. Insert the ribbon spindle into the ribbon core.

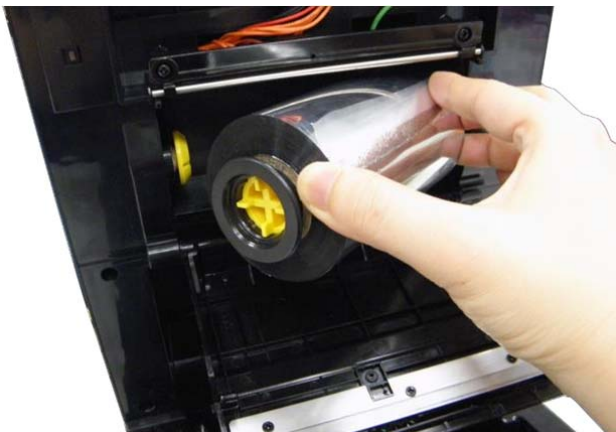
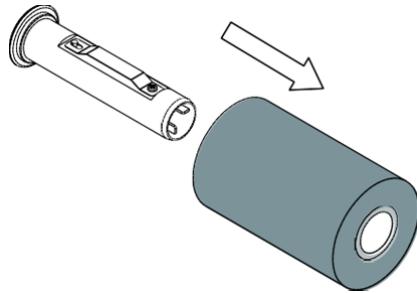

**Note:**  
The yellow part of spindle is in left side.

6. Install the ribbon right side onto the supply hub first then align the notches on the left side and mount onto the spokes.





7. Stick the ribbon onto the ribbon rewind paper core.

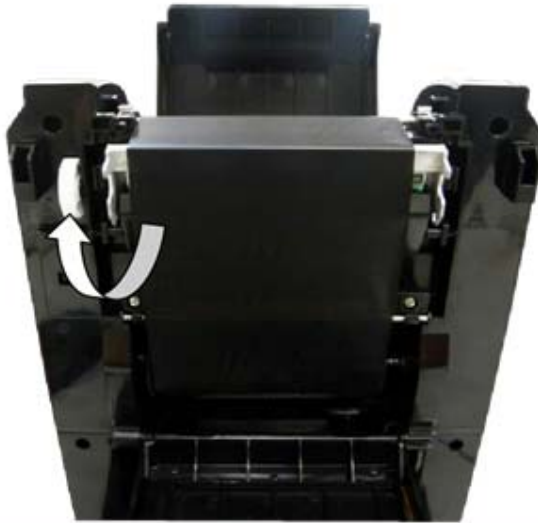

8. Turn the ribbon rewind gear until the ribbon plastic leader is thoroughly wound. Close the ribbon access cover and the top cover.



### Loading path for ribbon

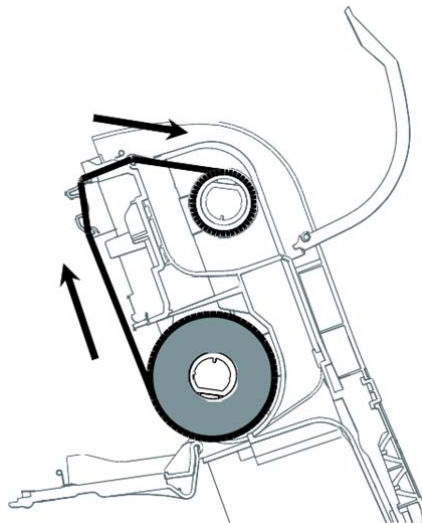

## 3.3 Loading the Media

### 3.3.1 Loading the Media



1. Open the printer top cover by pulling the tabs located on each side towards the front of the printer then lift the top cover to the maximum open angle.

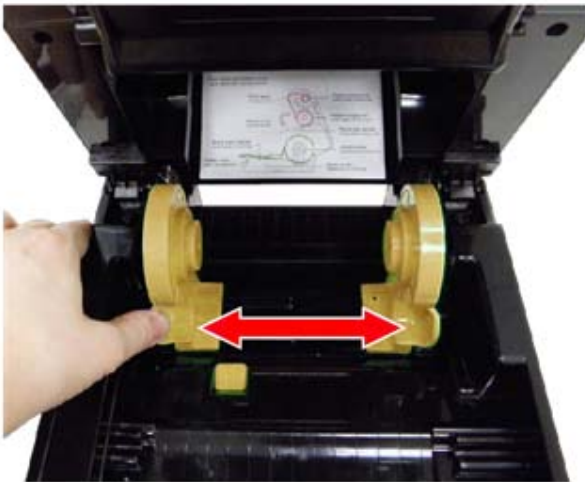

2. Separate and hold open the media holders.

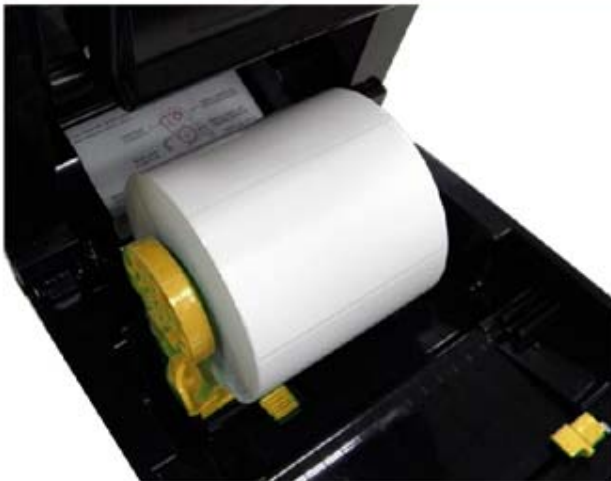

3. Place the roll between the holders and close them onto the core.





4. Place the paper, printing side face up, through the media sensor and place the label leading edge onto the platen roller.

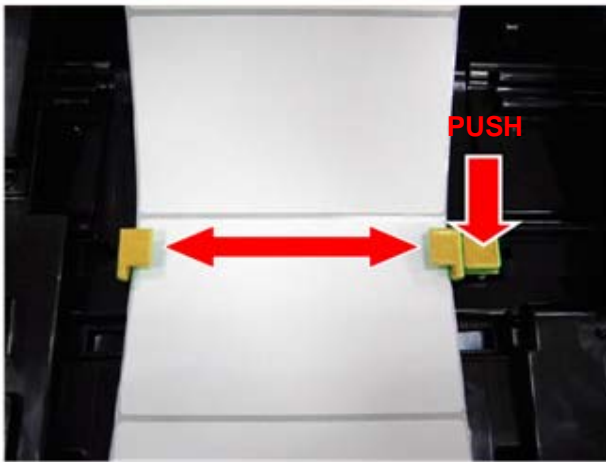

5. Move the media guides to fit the label width by pushing the media guide adjustment button.



6. Close the top cover gently.
7. Use "Diagnostic Tool" to set the media sensor type and calibrate the selected sensor. (Start the "Diagnostic tool" → Select the "Printer Configuration" tab → Click the "Calibrate Sensor" button ) Please refer to the diagnostic utility quick start guide for more information.

**Note:**  
Please calibrate the gap/black mark sensor when changing media.



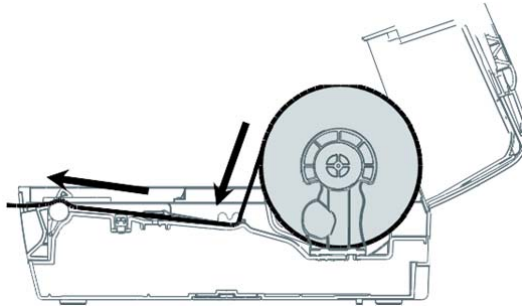

---

**Loading path for media**

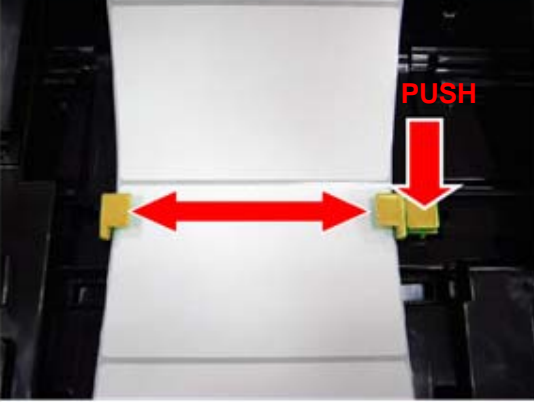

### 3.3.2 Loading Media in Cutter Mode (Option)

	<ol style="list-style-type: none"> <li>1. Please refer to section 3.3.1 to feed the paper, printing side face up, through the paper guide and pass over the platen.</li> </ol>										
	<ol style="list-style-type: none"> <li>2. Lead the paper through the cutter paper opening.</li> </ol>										
	<ol style="list-style-type: none"> <li>3. Move the media guides to fit the label width by pushing the media guide adjustment button.</li> </ol>										
	<ol style="list-style-type: none"> <li>4. Close the top cover gently.</li> <li>5. Use "Diagnostic Tool" to set the media sensor type, calibrate the selected sensor and set the post-print action to "CUTTER".</li> </ol> <table border="1" data-bbox="917 1564 1339 1732"> <tr> <td>Post-Print Action</td> <td>▼</td> </tr> <tr> <td>Cut Piece</td> <td>OFF</td> </tr> <tr> <td>Reference</td> <td>TEAR</td> </tr> <tr> <td></td> <td>PEEL</td> </tr> <tr> <td>Direction</td> <td>CUTTER</td> </tr> </table>	Post-Print Action	▼	Cut Piece	OFF	Reference	TEAR		PEEL	Direction	CUTTER
Post-Print Action	▼										
Cut Piece	OFF										
Reference	TEAR										
	PEEL										
Direction	CUTTER										

### 3.3.3 Loading Media in Peel-off Mode (Option)



1. Please refer to section 3.3.1 to feed the paper, printing side face up, through the paper guide and pass over the platen.

**Note:**  
This peel-off module is supported for the thermal/ plain label only.

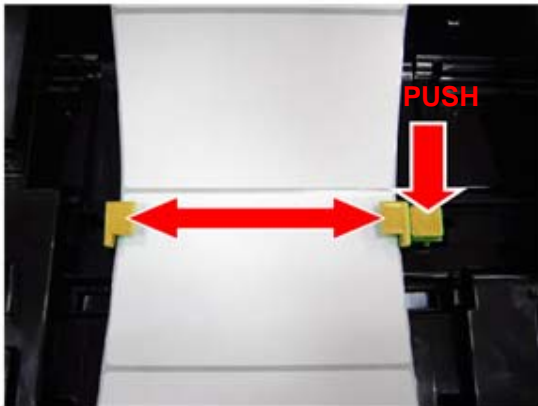

2. Move the media guides to fit the label width by pushing the media guide adjustment button.
3. Close the top cover gently. Use "Diagnostic Tool" to set the media sensor type, calibrate the selected sensor and set the post-print action to "PEEL".



**Note:**  
Please calibrate the sensor before loading media into the peel-off module for avoiding paper jam.



4. Open the top cover gently. Pull the label through the front of the printer and take some labels off only leave the liner.



5. Open the peel-off cover. Feed the liner into peel-off cover slot.

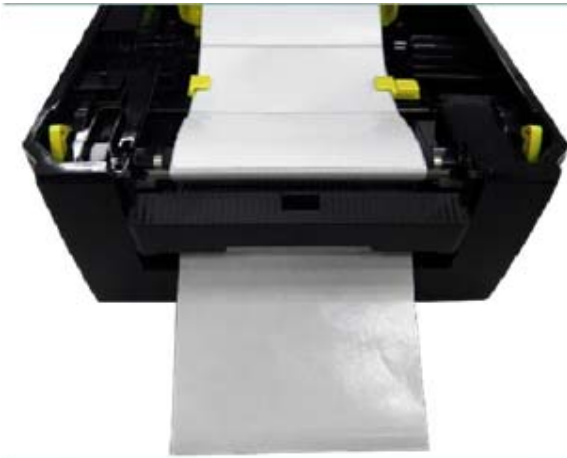

6. Close the peel-off cover and printer cover. Printer is ready for peel-off mode.





7. Print a label for test.

## 4. Diagnostic Tool

Wasp Barcode's Diagnostic Utility is an integrated tool incorporating features that enable you to explore a printer's settings/status; change a printer's settings; download graphics, fonts and firmware; create a printer bitmap font; and send additional commands to a printer. With the aid of this powerful tool, you can review printer status and setting in an instant, which makes it much easier to troubleshoot problems and other issues.

### 4.1 Start the Diagnostic Tool

1. Double click on the Diagnostic tool icon   to start the software.
2. There are four features (Printer Configuration, File Manager, Bitmap Font Manager, Command Tool) included in the Diagnostic utility.

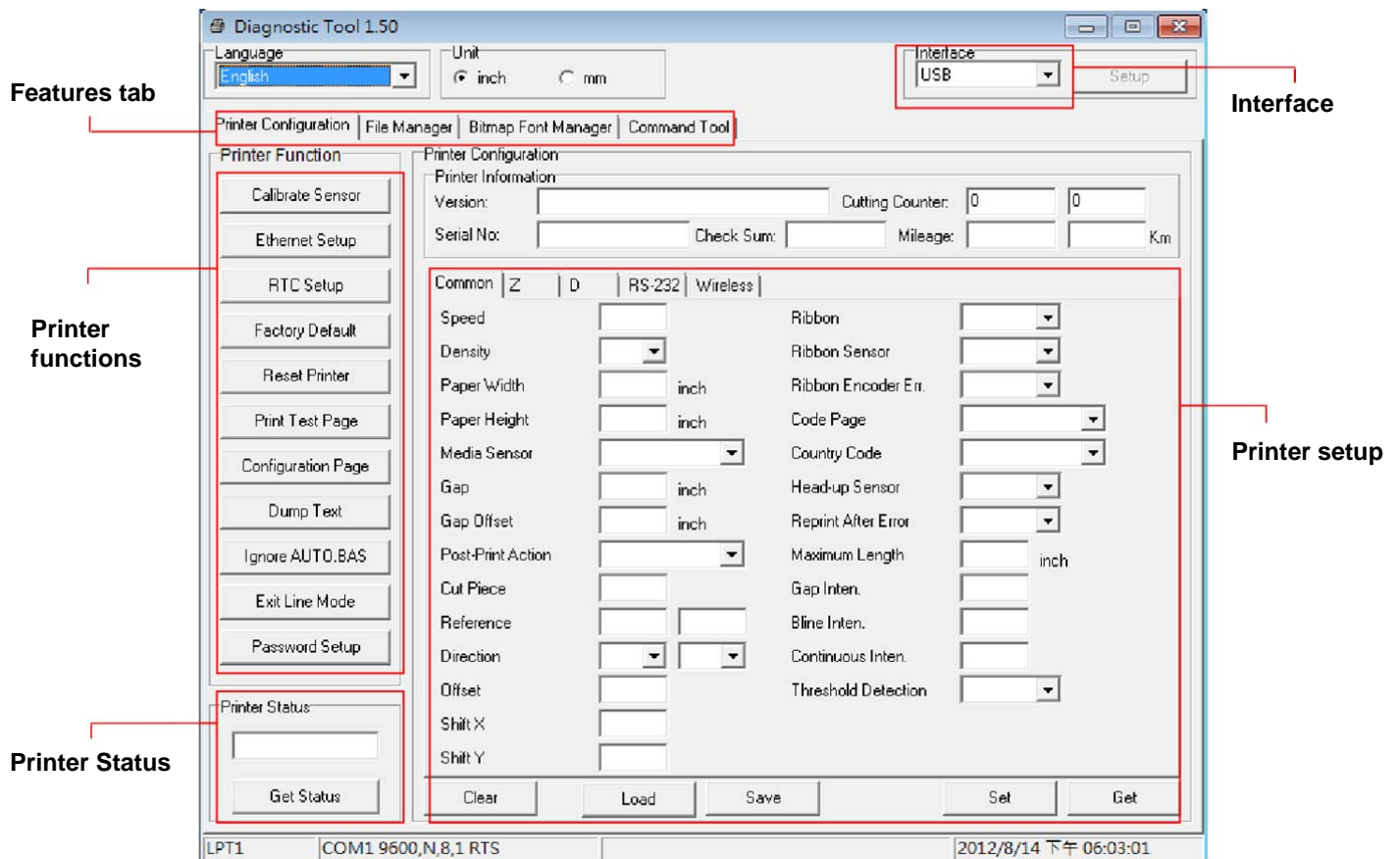

## 4.2 Printer Function

1. Connect the printer and computer with a cable.
2. Select the PC interface connected with bar code printer.

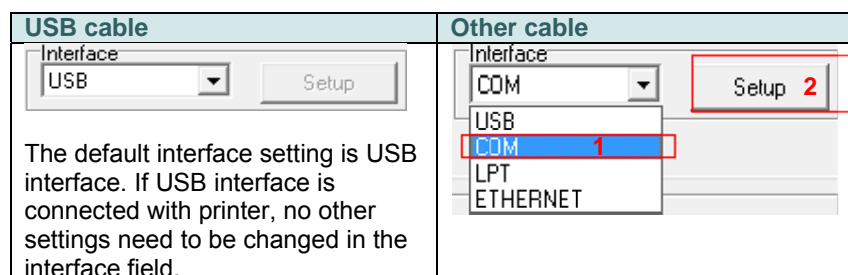

3. Click the “Printer Function” button to setup.
4. The detail functions in the Printer Function Group are listed as below.

Printer Function	Function	Description
Calibrate Sensor	Calibrate Sensor	Calibrate the sensor specified in the Printer Setup group media sensor field
Ethernet Setup	Ethernet Setup	Setup the IP address, subnet mask, gateway for the on board Ethernet
RTC Setup	RTC Setup	Synchronize printer Real Time Clock with PC
Factory Default	Factory Default	Initialize the printer and restore the settings to factory default.
Reset Printer	Reset Printer	Reboot printer
Print Test Page	Print Test Page	Print a test page
Configuration Page	Configuration Page	Print printer configuration
Dump Text	Dump Text	To activate the printer dump mode.
Ignore AUTO.BAS	Ignore AUTO.BAS	Ignore the downloaded AUTO.BAS program
Exit Line Mode	Exit Line Mode	Exit line mode.
Password Setup	Password Setup	Set the password to protect the settings

**For more information about Diagnostic Tool, please refer to the diagnostic utility quick start guide in the CD disk \ Utilities directory.**

## 4.3 Setting Ethernet by Diagnostic Tool

The Diagnostic Utility is enclosed in the CD disk Utilities directory. Users can use Diagnostic Tool to setup the Ethernet by RS-232, USB and Ethernet interfaces. The following contents will instruct users how to configure the Ethernet by these three interfaces.

### 4.3.1 Using USB interface to setup Ethernet interface

1. Connect the printer and computer with USB cable.
2. Turn on the printer power switch.
3. Start the Diagnostic Utility by double clicking on the  icon.
4. The Diagnostic Utility default interface setting is USB interface. If USB interface is connected with printer, no other settings need to be changed in the interface field.

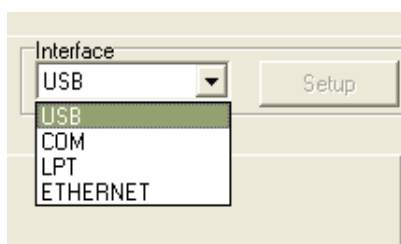

5. Click on the “Ethernet Setup” button from “Printer Function” group in Printer Configuration tab to setup the IP address, subnet mask and gateway for the on board Ethernet.

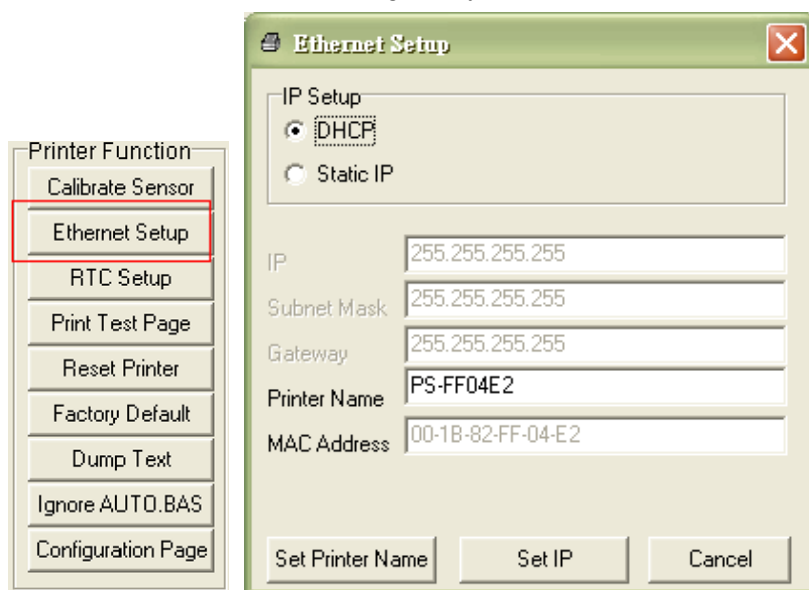

### 4.3.2 Using RS-232 interface to setup Ethernet interface

1. Connect the computer and the printer with a RS-232 cable.

2. Turn on the printer power.

3. Start the Diagnostic Utility by double clicks on the  `DiagTool.exe` icon.

4. Select “COM” as interface then click on the “Setup” button to setup the serial port baud rate, parity check, data bits, stop bit and flow control parameters.

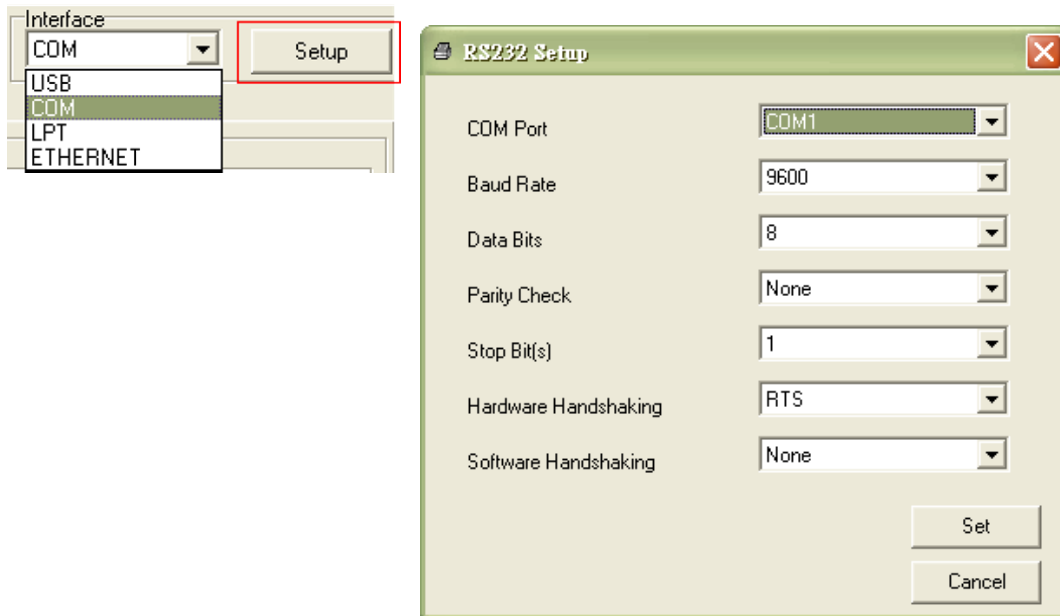

5. Click on the “Ethernet Setup” button from printer function of Printer Configuration tab to setup the IP address, subnet mask and the gateway for the on board Ethernet.

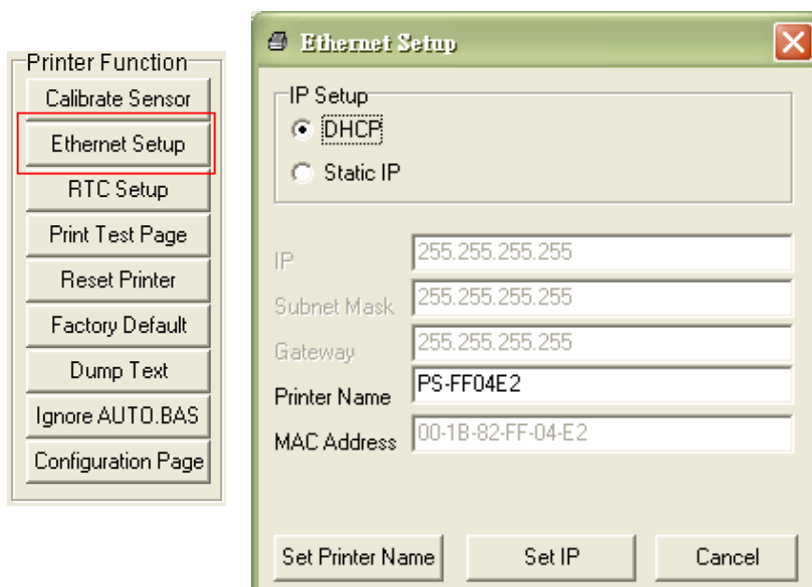



### 4.3.3 Using Ethernet interface to setup Ethernet interface

1. Connect the computer and the printer to the LAN.
2. Turn on the printer power.
3. Start the Diagnostic Utility by double clicks on the  **DiagTool.exe** icon.
4. Select “Ethernet” as the interface then click on the “Setup” button to setup the IP address, subnet mask and gateway for the on board Ethernet.

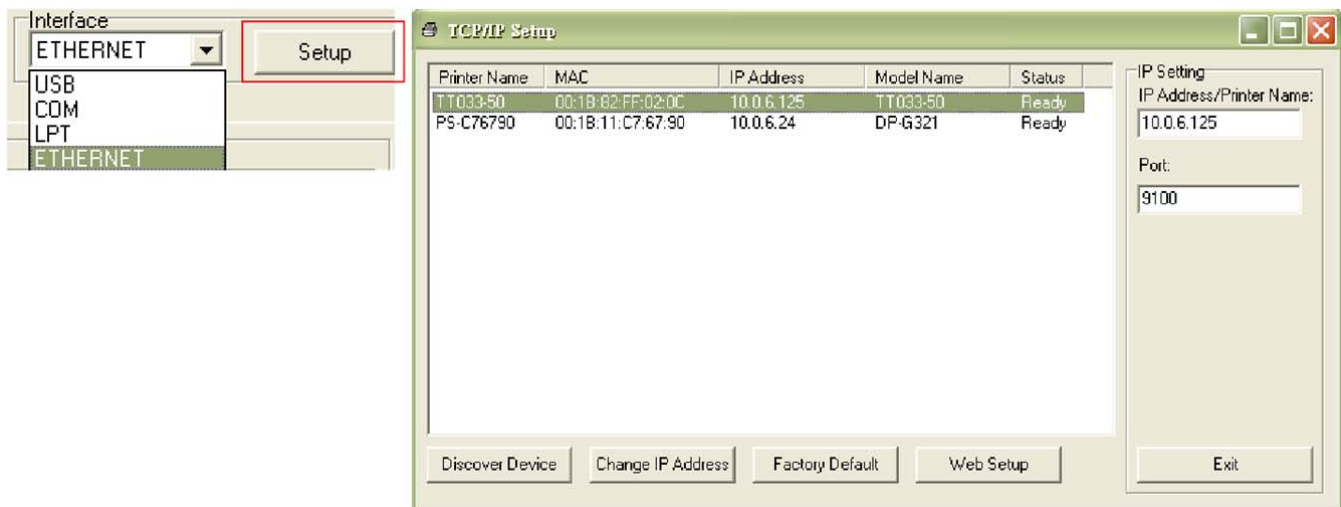

5. Click the “Discover Device” button to explore the printers that exist on the network.
6. Select the printer in the left side of listed printers, the correspondent IP address will be shown in the right side “IP address/Printer Name” field.
7. Click “Change IP Address” to configure the IP address obtained by DHCP or static.

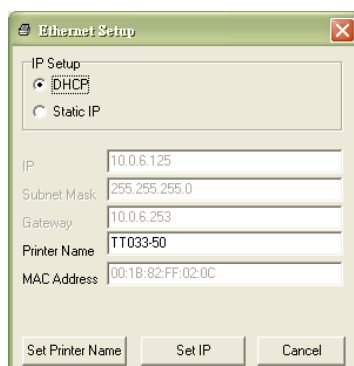

The default IP address is obtained by DHCP. To change the setting to static IP address, click "Static IP" radio button then enter the IP address, subnet mask and gateway. Click "Set IP" to take effect the settings.

Users can also change the "Printer Name" by another model name in this fields then click "Set Printer Name" to take effect this change.

***Note: After clicking the "Set Printer Name" or "Set IP" button, printer will reset to take effect the settings.***

8. Click "Exit" button to exit the Ethernet interface setup and go back to Diagnostic Tool main screen.

Factory Default button

This function will reset the IP, subnet mask, gateway parameters obtained by DHCP and reset the printer name.

Web setup button







Except to use the Diagnostic Utility to setup the printer, you can also explore and configure the printer settings and status or update the firmware with the IE or Firefox web browser. This feature provides a user friendly setup interface and the capability to manage the printer remotely over a network.

## 5. Power-on Utilities

There are six power-on utilities to set up and test printer hardware. These utilities are activated by pressing FEED button then turning on the printer power simultaneously and release the button at different status of LED.

Please follow the steps below for different power-on utilities.

1. Turn off the printer power switch.
2. Hold on the button then turn on the power switch.
3. Release the button when LED indicates with different status for different functions.

Power on utilities	The LED will be changed as following:					
LED color & status	Red	Red	Red	Red	Green	Green
Functions	 (5 blinks)	 (5 blinks)	 (5 blinks)	 (5 blinks)	 (5 blinks)	 (Solid)
<b>1. Ribbon sensor calibration and gap / black mark sensor calibration</b>	Release					
<b>2. Gap / black mark sensor calibration, Self-test and enter dump mode</b>		Release				
<b>3. Printer initialization</b>			Release			
<b>4. Set black mark sensor as media sensor and calibrate the black mark sensor</b>				Release		
<b>5. Set gap sensor as media sensor and calibrate the gap sensor</b>					Release	
<b>6. Skip AUTO.BAS</b>						Release

## 5.1 Ribbon and Gap/Black Mark Sensor Calibration

Gap/black mark sensor sensitivity should be calibrated at the following conditions:

1. A brand new printer
2. Change label stock
3. Printer initialization

Please follow the steps below to calibrate the ribbon and gap/black mark sensor.

1. Turn off the power switch.
2. Hold on the button then turn on the power switch.

3. Release the button when LED  becomes red and blinking.

- It will calibrate the ribbon sensor and gap/black mark sensor sensitivity.
- The LED will be changed as following order :

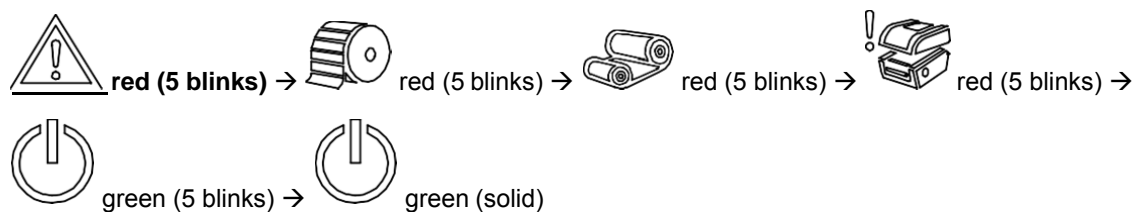

### Note:

Please select gap or black mark sensor by sending GAP or BLINE command to printer prior to calibrate the sensor.

For more information about GAP and BLINE command, please refer to WPL2 programming manual.

## 5.2 Gap/Black Mark Calibration, Self-test and Dump Mode

While calibrate the gap/black mark sensor, printer will measure the label length, print the internal configuration (self-test) on label and then enter the dump mode. To calibrate gap or black mark sensor, depends on the sensor setting in the last print job.

Please follow the steps below to calibrate the sensor.

1. Turn off the power switch.
2. Hold on the button then turn on the power switch.

3. Release the button when LED  becomes red and blinking.

- The LED will be changed as following order.

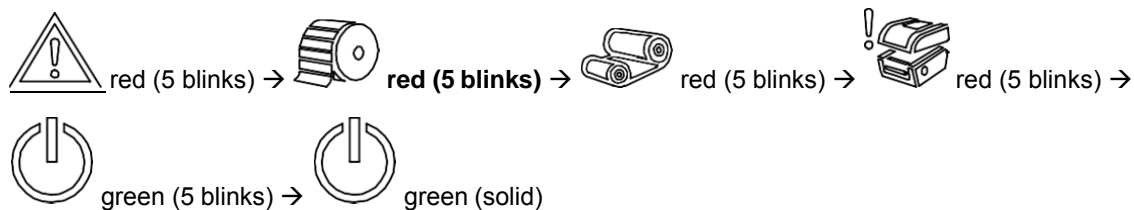

4. It calibrates the sensor and measures the label length and prints internal settings then enter the dump mode.

### Note:

Please select gap or black mark sensor by Diagnostic Tool or by GAP or BLINE command prior to calibrate the sensor.

For more information about GAP and BLINE command, please refer to WPL2 programming manual.

## ■ Self-test

Printer will print the printer configuration after gap/black mark sensor calibration. Self-test printout can be used to check if there is any dot damage on the heater element, printer configurations and available memory space.

Self-test printout	
<pre> ----- SYSTEM INFORMATION ----- MODEL: XXXXXX FIRMWARE: X.XX CHECKSUM: XXXXXXXX S/N: XXXXXXXXXXXX TCF: NO DATE: 1970/01/01 TIME: 00:04:18 NON-RESET: 110 m (TPH) RESET: 110 m (TPH) NON-RESET: 0 (CUT) RESET: 0 (CUT) ----- </pre>	<p>Model name</p> <p>F/W version</p> <p>Firmware checksum</p> <p>Printer S/N</p> <p>Configuration file</p> <p>System date</p> <p>System time</p> <p>Printed mileage (meter)</p> <p>Cutting counter</p>
<pre> ----- PRINTING SETTING ----- SPEED: 5 IPS DENSITY: 8.0 WIDTH: 4.00 INCH HEIGHT: 4.00 INCH GAP: 0.00 INCH INTENSION: 5 CODEPAGE: 850 COUNTRY: 001 ----- </pre>	<p>Print speed (inch/sec)</p> <p>Print darkness</p> <p>Label size (inch)</p> <p>Gap distance (inch)</p> <p>Gap/black mark sensor intension</p> <p>Code page</p> <p>Country code</p>
<pre> ----- Z SETTING ----- DARKNESS: 16.0 SPEED: 4 IPS WIDTH: 4.00 INCH TILDE: 7EH (~) CARET: 5EH (^) DELIMITER: 2CH (,) POWER UP: NO MOTION HEAD CLOSE: NO MOTION ----- </pre>	<p>ZPL setting information</p> <p>Print darkness</p> <p>Print speed (inch/sec)</p> <p>Label size</p> <p>Control prefix</p> <p>Format prefix</p> <p>Delimiter prefix</p> <p>Printer power up motion</p> <p>Printer head close motion</p> <p><b>Note:</b> ZPL is emulating for Zebra® language.</p>
<pre> ----- RS232 SETTING ----- BAUD: 9600 PARITY: NONE DATA BIT: 8 STOP BIT: 1 ----- </pre>	<p>RS232 serial port configuration</p>

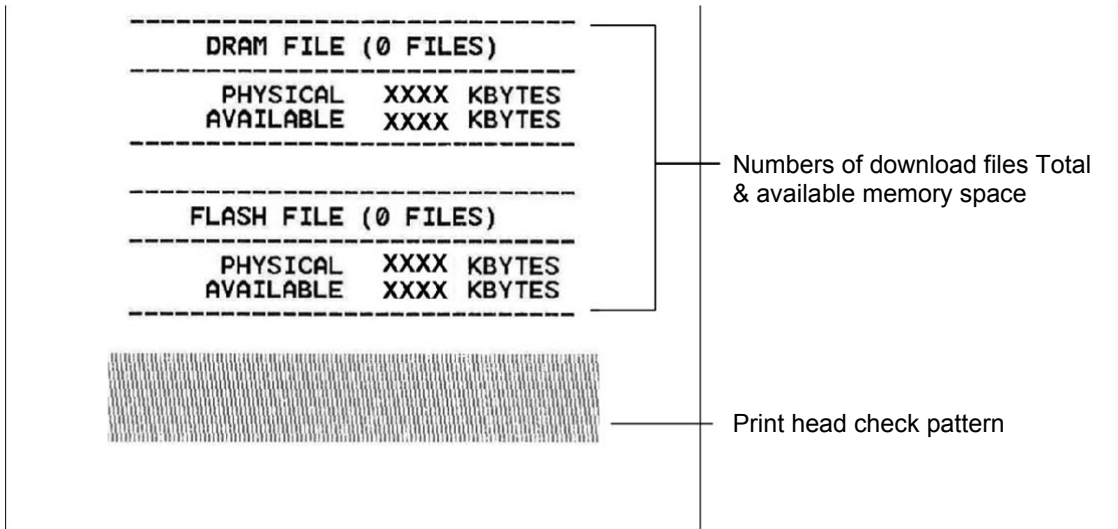



## ■ Dump mode

Printer will enter dump mode after printing printer configuration. In the dump mode, all characters will be printed in 2 columns as following. The left side characters are received from your system and right side data are the corresponding hexadecimal value of the characters. It allows users or engineers to verify and debug the program.

ASCII Data	→	<pre> SPEED 2.0 53 50 45 45 44 20 32 2E 30 0D DENSITY 8 0A 44 45 4E 53 49 54 59 20 38 SET PEEL 0D 0A 53 45 54 20 50 45 45 4C OFF DIRE 20 4F 46 46 0D 0A 44 49 52 45 CTION 0 G 43 54 49 4F 4E 20 30 0D 0A 47 AP 3.00 mm 41 50 20 39 2E 30 30 20 6D 6D .0.00 mm 2C 30 2E 30 30 20 6D 6D 0D 0A REFERENCE 52 45 46 45 52 45 4E 43 45 20 0.0 SET C 30 2C 30 0D 0A 53 45 54 20 43 UTTER OFF 55 54 54 45 52 20 4F 46 46 0D SIZE 100. 0A 53 49 5A 45 20 31 30 30 2E 02 mm.65.0 30 32 20 6D 6D 2C 36 35 2E 30 4 mm CLS 34 20 6D 6D 0D 0A 43 4C 53 0D BARCODE 1 0A 42 41 62 43 4F 44 45 20 31 44.149."39 34 34 2C 31 34 39 2C 22 33 39 ".120.1.0. 22 2C 31 32 30 2C 31 2C 30 2C 2.6."57114 32 2C 36 2C 22 35 37 31 31 34 3BT" PRIN 33 38 54 22 0D 0A 50 52 49 4E T 1.1 SPE 54 20 31 2C 31 0D 0A 53 50 45 ED 2.0 DE 45 44 20 32 2E 30 0D 0A 44 46 NSITY 8 S 4E 53 49 64 69 20 38 0D 0A 63  ET PEEL OF 45 54 20 50 45 45 4C 20 4F 46 F DIRECTI 46 0D 0A 44 49 62 45 43 54 49 ON 0 GAP 4F 4E 20 30 0D 0A 47 41 50 20 3.00 mm.0. 33 2E 30 30 20 6D 6D 2C 30 2E 00 mm REF 30 30 20 6D 6D 0D 0A 52 45 46 ERENCE 0.0 45 52 45 4E 43 45 20 30 2C 30 SET OUTT 0D 0A 53 45 54 20 43 55 54 54 RE OFF SI 45 52 20 4F 46 46 0D 0A 53 49 ZE 100 02 5A 45 20 31 30 30 2E 30 32 20 mm.65.04 m 6D 6D 2C 36 35 2E 30 34 20 6D m CLS BA 6D 0D 0A 43 4C 53 0D 0A 42 41 RCODE 144. 52 43 4F 44 45 20 31 34 34 2C 149."39" 1 31 34 39 2C 22 33 39 22 2C 31 20.i.0.2.0 32 30 2C 31 2C 30 2C 32 2C 36 ".571143BT 22 22 35 37 31 31 34 33 38 54 " PRINT 1 22 0D 0A 50 52 49 4E 64 20 31 .1 2C 31 0D 0A </pre>	← Hex decimal data related to left column of ASCII data
------------	---	--	---

### Note:

1. Dump mode requires 4" wide paper width.
2.  &  LEDs will be turned on when at dump mode.
3. Turn off / on the power to resume printer for normal printing.



## 5.3 Printer Initialization

Printer initialization is used to clear DRAM and restore printer settings to defaults. The only one exception is ribbon sensitivity, which will not be restored to default.

Printer initialization is activated by the following procedures.

1. Turn off the power switch.
2. Hold on the button then turn on the power switch.
3. Release the button when LED  turns red and 5 blinks.

- The LED will be changed as following:

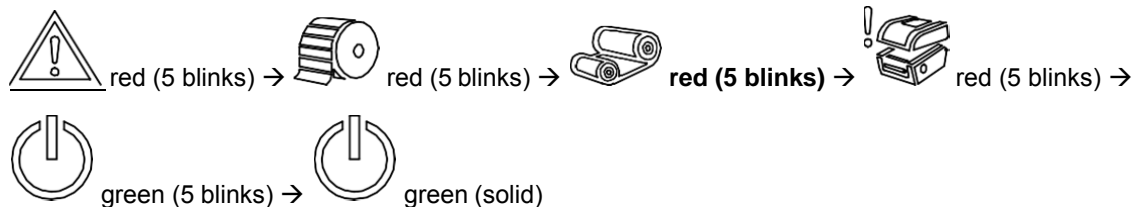

Printer configuration will be restored to defaults as below after initialization.

Parameter	Default setting
Speed	101.6 mm/sec (4 ips) (203DPI) 76 mm/sec (3 ips) (300DPI)
Density	8
Label Width	4" (101.5 mm)
Label Height	4" (101.5 mm)
Sensor Type	Gap sensor
Gap Setting	0.12" (3.0 mm)
Print Direction	0
Reference Point	0,0 (upper left corner)

Offset	0
Tear Mode	On
Peel off Mode	Off
Cutter Mode	Off
Serial Port Settings	9600 bps, none parity, 8 data bits, 1 stop bit
Code Page	850
Country Code	001
Clear Flash Memory	No
IP Address	DHCP

## 5.4 Set Black Mark Sensor as Media Sensor and Calibrate the Black Mark Sensor

Please follow the steps as below.

1. Turn off the power switch.
2. Hold on the button then turn on the power switch.

3. Release the button when LED  turns red and 5 blinks.

- The LED will be changed as following:

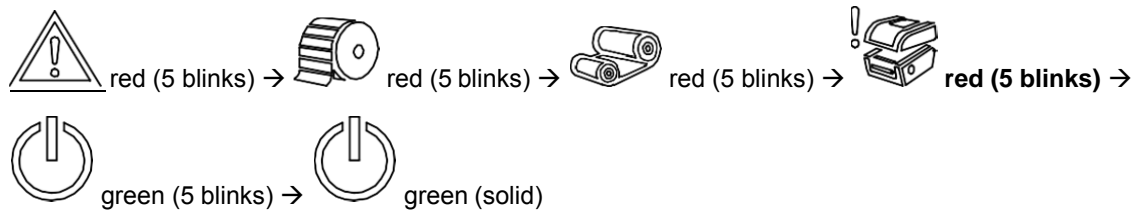

# 5.5 Set Gap Sensor as Media Sensor and Calibrate the Gap Sensor

Please follow the steps as below.

- 1. Turn off the power switch.
- 2. Hold on the button then turn on the power switch.

3. Release the button when LED  turns **green** and 5 blinks.

■ The LED will be changed as following:

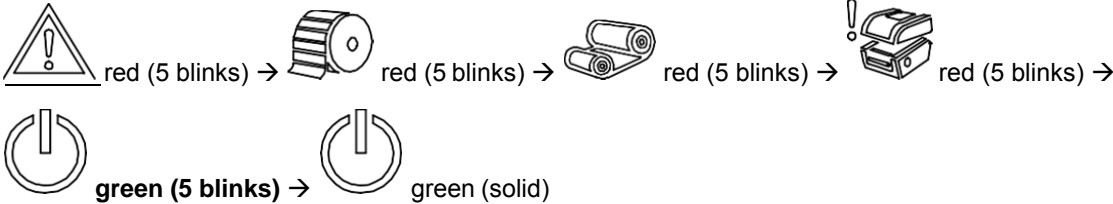

## 5.6 Skip AUTO.BAS

WPL2 programming language allows user to download an auto execution file to flash memory. Printer will run the AUTO.BAS program immediately when turning on printer power. The AUTO.BAS program can be interrupted without running the program by the power-on utility.

Please follow the procedures below to skip an AUTO.BAS program.

1. Turn off printer power.
2. Press the FEED button and then turn on power.

3. Release the FEED button when LED  becomes **solid green**.

- The LED will be changed as following:

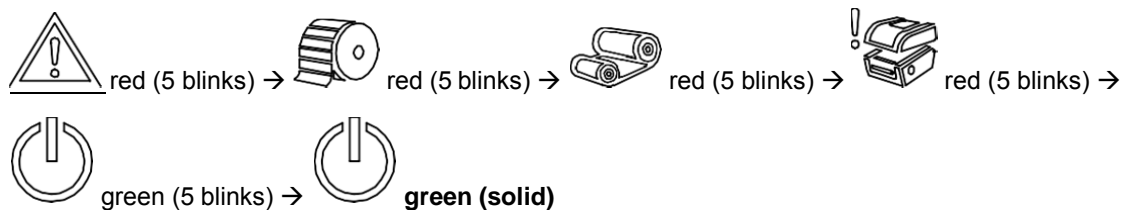

4. Printer will be interrupted to run the AUTO.BAS program.

## 6. LCD Menu Function

### 6.1 Enter the Menu

Press the “Menu” button to enter the main menu. Use the “Cross” button to select the item on main menu. The selected item will turn red. Press the “Feed” button to enter the setting list.

**Note:** This LCD function is optional for WPL308 series.

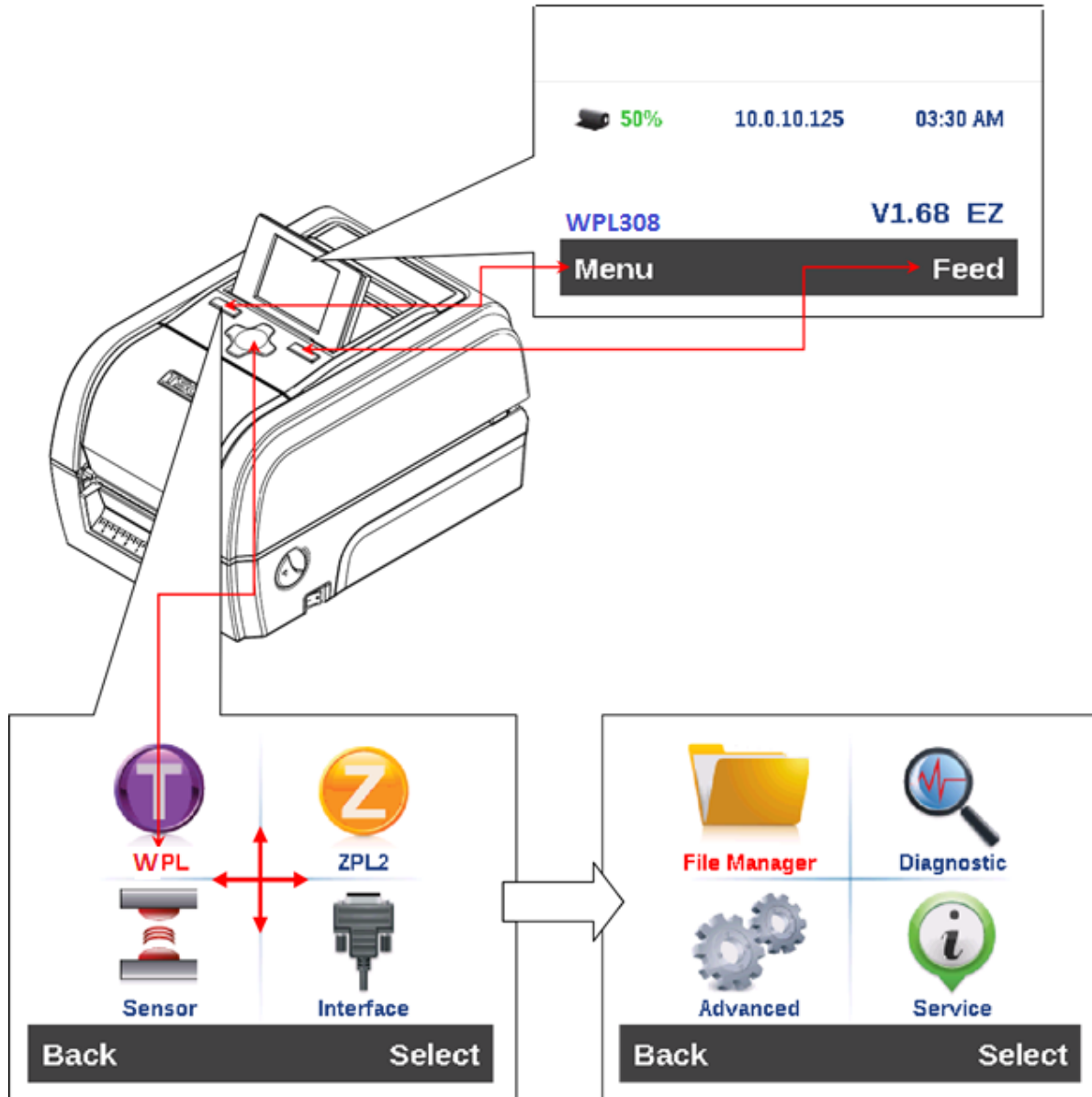

## 6.2 Main Menu Overview

There are 8 categories for the main menu. You can easily set the settings of printer without connecting the computer. Please refer to following sections for more details.

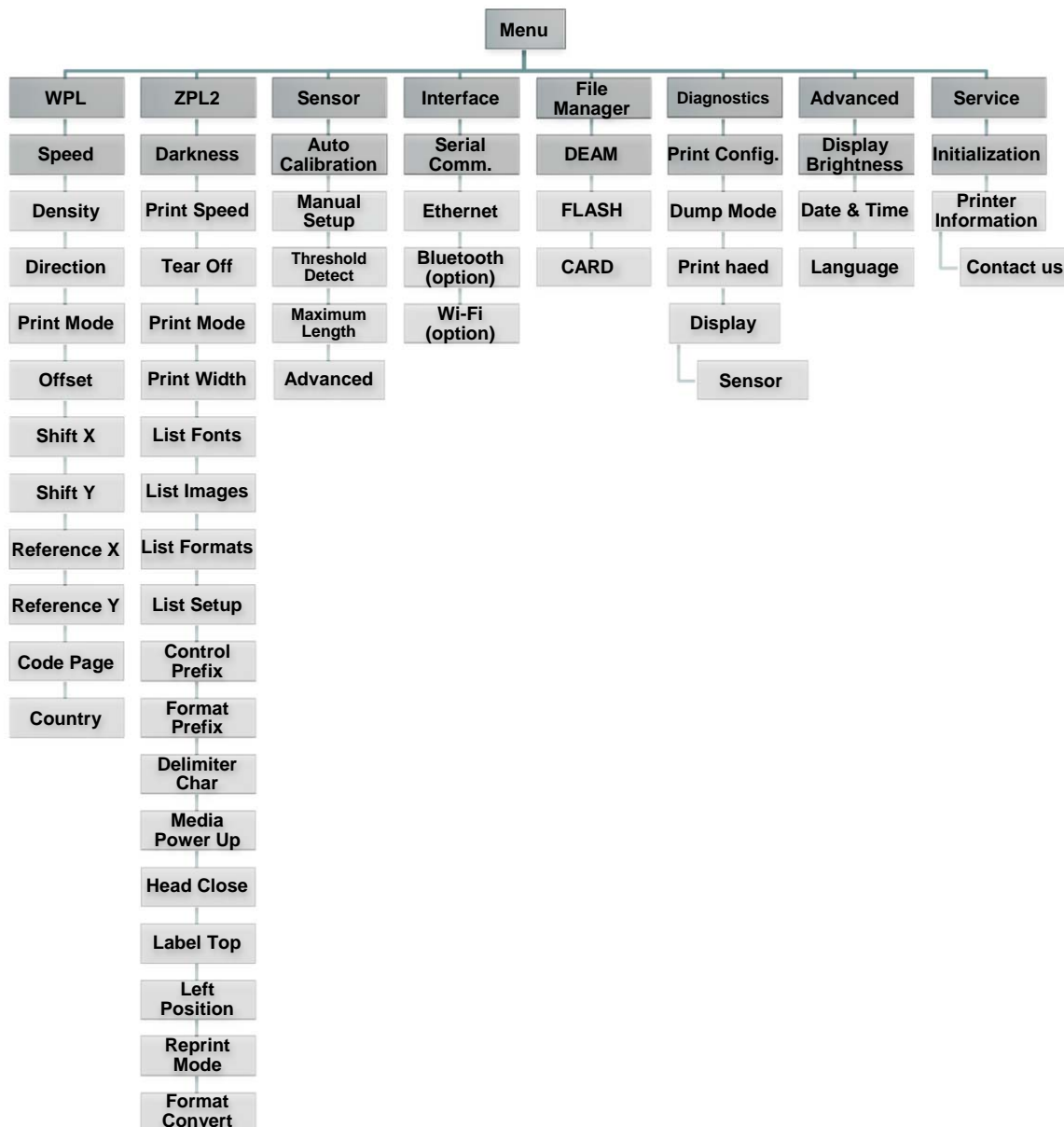

## 6.3 WPL2

This “WPL2” category can set up the printer settings for WPL2.

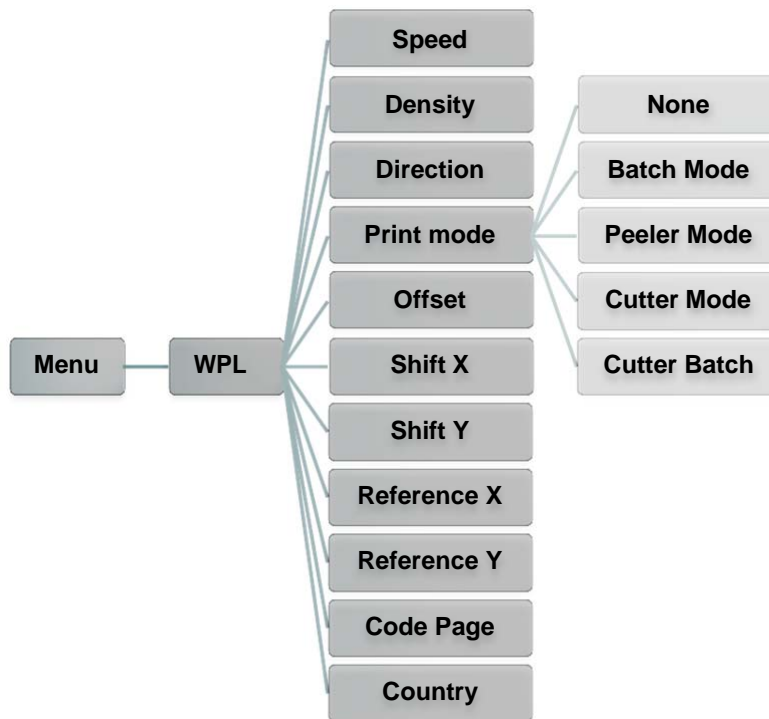

Item	Description	Default								
<b>Speed</b>	Use this item to setup print speed.	<b>N/A</b>								
<b>Density</b>	Use this option to setup printing darkness. The available setting is from 0 to 15, and the step is 1. You may need to adjust your density based on selected media.	<b>8</b>								
<b>Direction</b>	<p>The direction setting value is either 1 or 0. Use this item to setup the printout direction.</p>	<b>0</b>								
<b>Print mode</b>	<p>This item is used to set the print mode. There are 5 modes as below,</p> <table border="1"> <thead> <tr> <th>Printer Mode</th> <th>Description</th> </tr> </thead> <tbody> <tr> <td>None</td> <td>Next label top of form is aligned to the print head burn line location. (Tear Off Mode)</td> </tr> <tr> <td>Batch Mode</td> <td>Once image is printed completely, label gap/black mark will be fed to the tear plate location for tear away.</td> </tr> <tr> <td>Peeler Mode</td> <td>Enable the label peel off mode.</td> </tr> </tbody> </table>	Printer Mode	Description	None	Next label top of form is aligned to the print head burn line location. (Tear Off Mode)	Batch Mode	Once image is printed completely, label gap/black mark will be fed to the tear plate location for tear away.	Peeler Mode	Enable the label peel off mode.	<b>Batch Mode</b>
Printer Mode	Description									
None	Next label top of form is aligned to the print head burn line location. (Tear Off Mode)									
Batch Mode	Once image is printed completely, label gap/black mark will be fed to the tear plate location for tear away.									
Peeler Mode	Enable the label peel off mode.									



	Cutter Mode	Enable the label cutter mode.	
	Cutter Batch	Cut the label once at the end of the printing job.	
<b>Offset</b>	This item is used to fine tune media stop location. Available setting value is from “+” to “-” or “0” to “9”.		<b>+000</b>
<b>Shift X</b>	This item is used to fine tune print position. Available setting value is from “+” to “-” or “0” to “9”.		<b>+000</b>
<b>Shift Y</b>			<b>+000</b>
<b>Reference X</b>	This item is used to set the origin of printer coordinate system horizontally and vertically. Available setting value is from “0” to “9”.		<b>000</b>
<b>Reference Y</b>			<b>000</b>
<b>Code page</b>	Use this item to set the code page of international character set.		<b>850</b>
<b>Country</b>	Use this option to set the country code.		<b>001</b>

***Note: If printing from enclosed software/driver, the software/driver will send out the commands, which will overwrite the settings set from the panel.***

## 6.4 ZPL2

This “ZPL2” category can set up the printer settings for ZPL2.

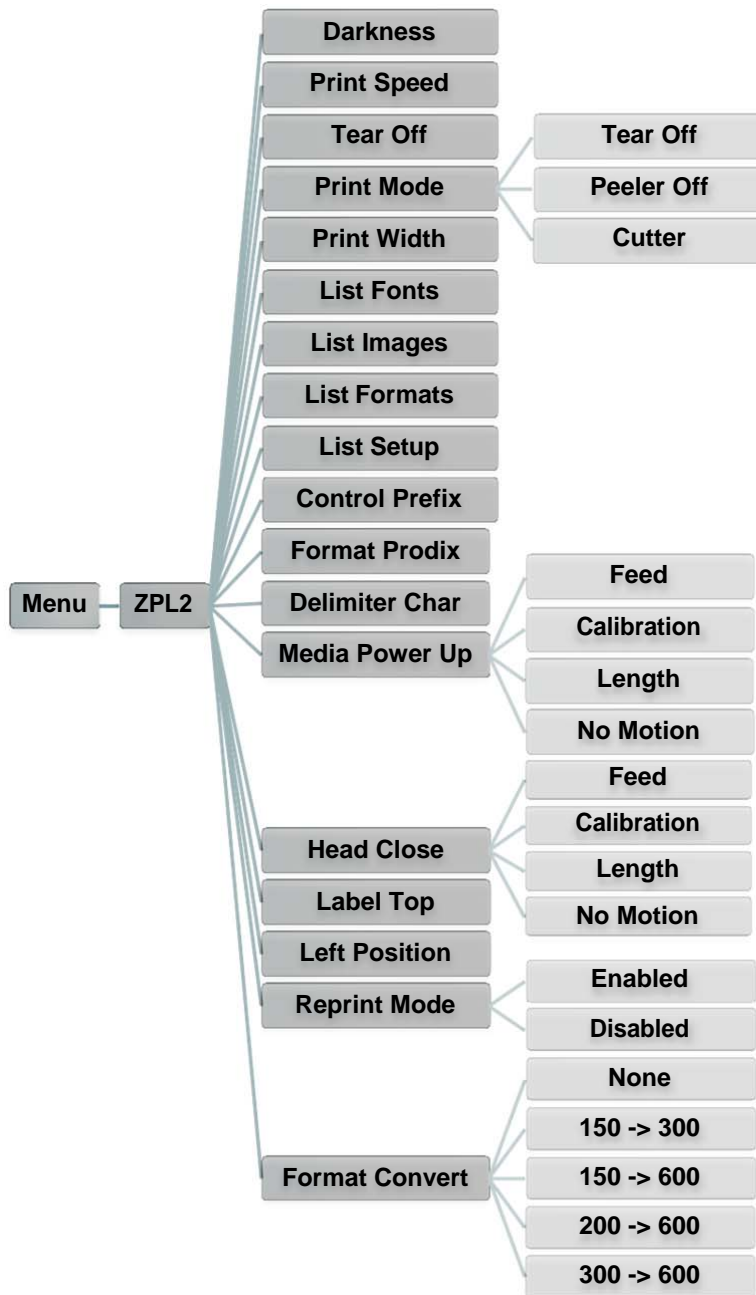

Item	Description	Default
<b>Darkness</b>	Use this item to setup printing darkness. The available setting is from 0 to 30, and the step is 1. You may need to adjust your density based on selected media.	<b>16</b>

<b>Print Speed</b>	Use this item to setup print speed. The each increase or decrease is 1 ips. Available setting is from 2 to 6.	6 (203dpi) 4 (300dpi) 3 (600dpi)										
<b>Tear Off</b>	This item is used to fine tune media stop location. Available setting value is from "+" to "-" or "0" to "9".	+000										
<b>Print mode</b>	<p>This item is used to set the print mode. There are 3 modes as below,</p> <table border="1"> <thead> <tr> <th>Printer Mode</th> <th>Description</th> </tr> </thead> <tbody> <tr> <td>Tear Off</td> <td>Next label top of form is aligned to the print head burn line location.</td> </tr> <tr> <td>Peeler Off</td> <td>Enable the label peel off mode.</td> </tr> <tr> <td>Cutter</td> <td>Enable the label cutter mode</td> </tr> </tbody> </table>	Printer Mode	Description	Tear Off	Next label top of form is aligned to the print head burn line location.	Peeler Off	Enable the label peel off mode.	Cutter	Enable the label cutter mode	<b>Tear Off</b>		
Printer Mode	Description											
Tear Off	Next label top of form is aligned to the print head burn line location.											
Peeler Off	Enable the label peel off mode.											
Cutter	Enable the label cutter mode											
<b>Print Width</b>	This item is used to set print width. The available value is from "0" to "9".	N/A										
<b>List Fonts</b>	This feature is used to print current printer available fonts list to the label. The fonts stored in the printer's DRAM, Flash or optional memory card.	N/A										
<b>List Images</b>	This feature is used to print current printer available images list to the label. The images stored in the printer's DRAM, Flash or optional memory card.	N/A										
<b>List Formats</b>	This feature is used to print current printer available formats list to the label. The formats stored in the printer's DRAM, Flash or optional memory card.	N/A										
<b>List Setup</b>	This feature is used to print current printer configuration to the label.	N/A										
<b>Control Prefix</b>	This feature is used to set control prefix character.	N/A										
<b>Format Prefix</b>	This feature is used to set format prefix character.	N/A										
<b>Delimiter Char</b>	This feature is used to set delimiter character.	N/A										
<b>Media Power Up</b>	<p>This option is used to set the action of the media when you turn on the printer.</p> <table border="1"> <thead> <tr> <th>Selections</th> <th>Description</th> </tr> </thead> <tbody> <tr> <td>Feed</td> <td>Printer will advance one label</td> </tr> <tr> <td>Calibration</td> <td>Printer will calibration the sensor levels, determine length and feed label</td> </tr> <tr> <td>Length</td> <td>Printer determine length and feed label</td> </tr> <tr> <td>No Motion</td> <td>Printer will not move media</td> </tr> </tbody> </table>	Selections	Description	Feed	Printer will advance one label	Calibration	Printer will calibration the sensor levels, determine length and feed label	Length	Printer determine length and feed label	No Motion	Printer will not move media	<b>No Motion</b>
Selections	Description											
Feed	Printer will advance one label											
Calibration	Printer will calibration the sensor levels, determine length and feed label											
Length	Printer determine length and feed label											
No Motion	Printer will not move media											
<b>Head Close</b>	<p>This option is used to set the action of the media when you close the print head.</p> <table border="1"> <thead> <tr> <th>Selections</th> <th>Description</th> </tr> </thead> <tbody> <tr> <td>Feed</td> <td>Printer will advance one label</td> </tr> <tr> <td>Calibration</td> <td>Printer will calibration the sensor levels, determine length and feed label</td> </tr> <tr> <td>Length</td> <td>Printer determine length and feed label</td> </tr> <tr> <td>No Motion</td> <td>Printer will not move media</td> </tr> </tbody> </table>	Selections	Description	Feed	Printer will advance one label	Calibration	Printer will calibration the sensor levels, determine length and feed label	Length	Printer determine length and feed label	No Motion	Printer will not move media	<b>No Motion</b>
Selections	Description											
Feed	Printer will advance one label											
Calibration	Printer will calibration the sensor levels, determine length and feed label											
Length	Printer determine length and feed label											
No Motion	Printer will not move media											
<b>Label Top</b>	This option is used to adjust print position vertically on the label. The range is -120 to +120 dots.	0										

<b>Left Position</b>	This option is used to adjust print position horizontally on the label. The range is -9999 to +9999 dots.	<b>+0000</b>
<b>Reprint Mode</b>	When reprint mode is enabled, you can reprint the last label printer by pressing “UP” button on printer’s control panel.	<b>Disabled</b>
<b>Format Convert</b>	Selects the bitmap scaling factor. The first number is the original dots per inch (dpi) value; the second, the dpi to which you would like to scale.	<b>None</b>

***Note: If printing from enclosed software/driver, the software/driver will send out the commands, which will overwrite the settings set from the panel.***

## 6.5 Sensor

This option is used to calibrate the selected sensor. We recommend calibrate the sensor before printing when changing the media.

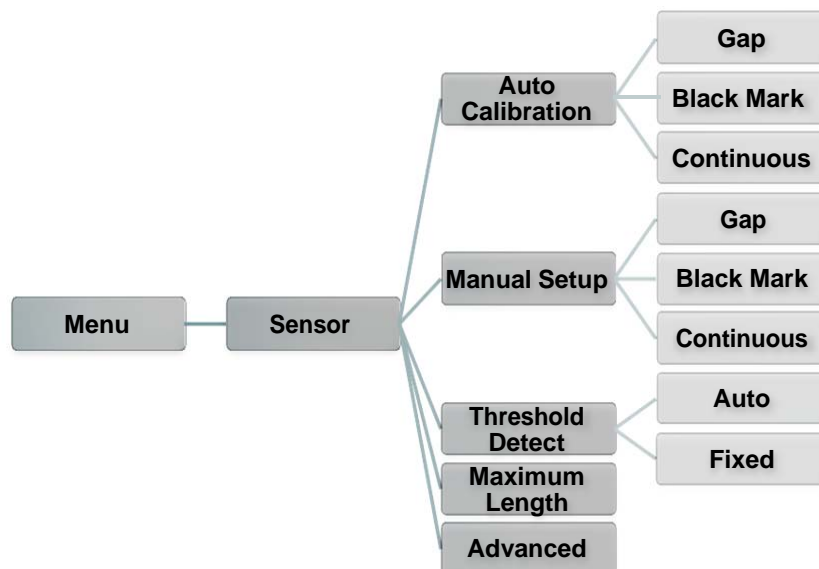

Item	Description	Default
<b>Auto Calibration</b>	Printer will feed 2 to 3 gap labels to calibrate the sensor sensitivity automatically.	<b>N/A</b>
<b>Manual Setup</b>	In case “Auto calibration” cannot apply to the media, please use “Manual setup” function to calibrate the sensor sensitivity.	<b>N/A</b>
<b>Threshold Detect</b>	This option is used to set sensor sensitivity in fixed or auto.	<b>Auto</b>
<b>Maximum Length</b>	This option is used to set the maximum length for label calibration.	<b>254mm</b>
<b>Advanced</b>	This function can set the minimum paper length and maximum gap/bline length for auto-calibrate the sensor sensitivity.	<b>OFF</b>

## 6.6 Interface

This option is used to set the printer interface settings.

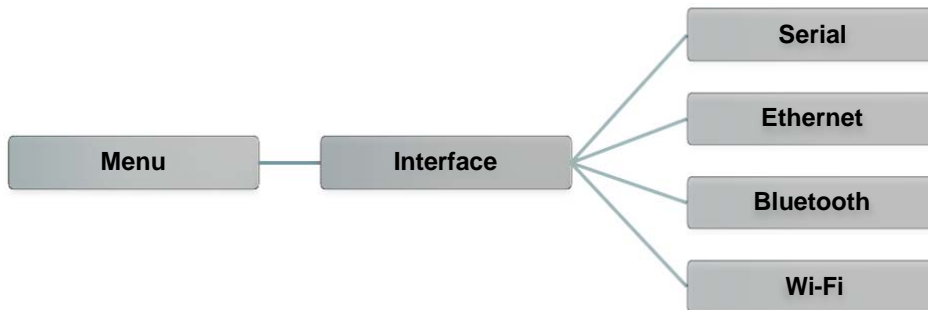

### 6.6.1 Serial Comm.

This option is used to set the printer RS-232 settings.

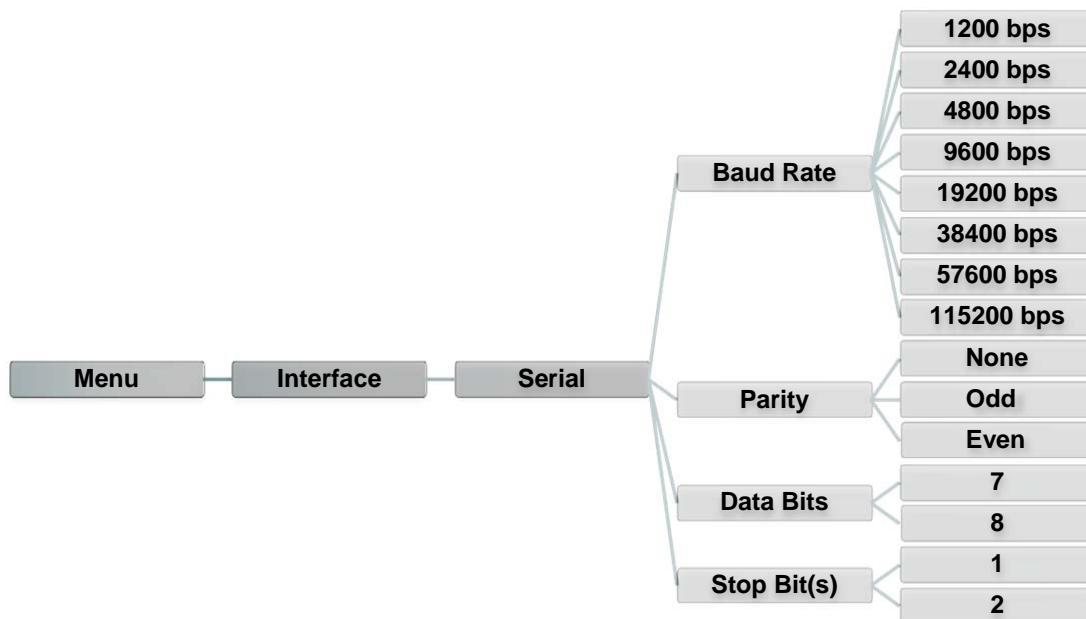

Item	Description	Default
<b>Baud Rate</b>	This item is used to set the RS-232 baud rate.	<b>9600</b>
<b>Parity</b>	This item is used to set the RS-232 parity.	<b>None</b>
<b>Data Bits</b>	This item is used to set the RS-232 Data Bits.	<b>8</b>
<b>Stop Bit(s)</b>	This item is used to set the RS-232 Stop Bits.	<b>1</b>

## 6.6.2 Ethernet

Use this menu to configure internal Ethernet configuration check the printer's Ethernet module status, and reset the Ethernet module.

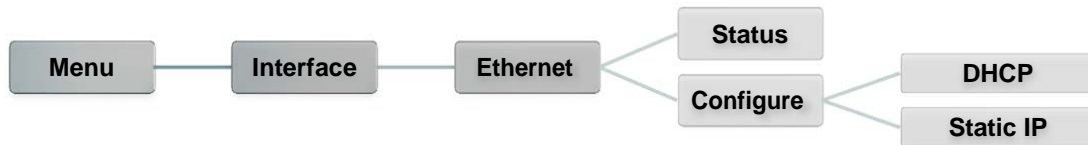

Item	Description	Default
Status	Use this menu to check the Ethernet IP address and MAC setting status.	N/A
DHCP	This item is used to ON or OFF the DHCP (Dynamic Host Configuration Protocol) network protocol.	N/A
Static IP	Use this menu to set the printer's IP address, subnet mask and gateway.	ON

### 6.6.3 Bluetooth

This option is used to set the printer Bluetooth settings.

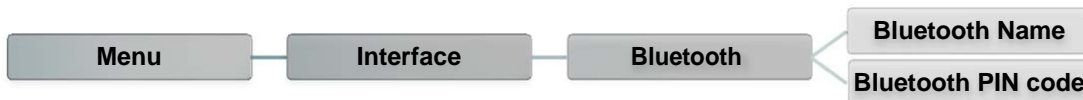

Item	Description	Default
<b>Bluetooth Name</b>	This item is used to set the local name for Bluetooth.	<b>BT-SPP</b>
<b>Bluetooth PIN Code</b>	This item is used to set the local PIN code for Bluetooth.	<b>0000</b>

### 6.6.4 Wi-Fi

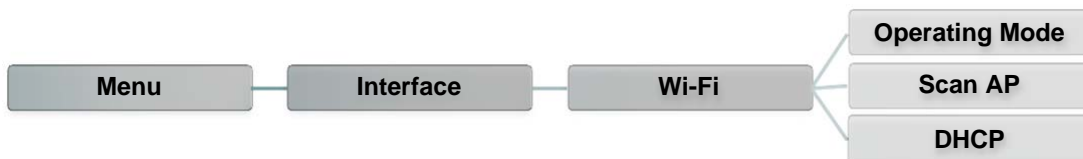

Item	Description	Default
<b>Operating</b>	This item is used to set the operating mode of wireless local area networks to connect devices to the networks.  <b>Note:</b> <b>Infrastructure mode requires the use of an access point for this communication to take place.</b> <b>Ad hoc mode involves connecting a computer directly to another computer.</b>	<b>Infrastructure</b>
<b>Scan AP</b>	This item is used to scan the access point device	<b>N/A</b>
<b>DHCP</b>	This item is used to ON or OFF the DHCP (Dynamic Host Configuration Protocol) network protocol.	<b>ON</b>



# 6.7 File Manager

This feature is used to check the printer available memory and file list.



Item	Description
<b>DRAM</b>	Use this menu to show, delete and run (.BAS) the files saved in the printer DRAM memory.
<b>FLASH</b>	Use this menu to show, delete and run (.BAS) the files saved in the printer Flash memory.
<b>CARD</b>	Use this menu to show, delete and run (.BAS) the files saved in the printer Card memory.

## 6.8 Diagnostics

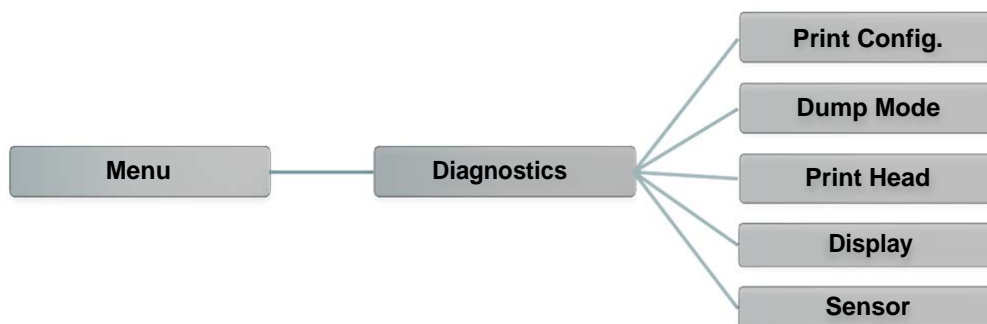

### 6.8.1 Print Config.

This feature is used to print current printer configuration to the label. On the configuration printout, there is a print head test pattern, which is useful for checking if there is any dot damage on the print head heater element.



Self-test printout	
-----	
SYSTEM INFORMATION	
-----	
MODEL: xxxxxx	Model name
FIRMWARE: x.xx	F/W version
CHECKSUM: xxxxxxxx	Firmware checksum
S/N: xxxxxxxxxxxx	Printer S/N
TCF: NO	Configuration file
DATE: 1970/01/01	System date
TIME: 00:04:18	System time
NON-RESET: 110 m (TPH)	Printed mileage (meter)
RESET: 110 m (TPH)	
NON-RESET: 0 (CUT)	Cutting counter
RESET: 0 (CUT)	
-----	
PRINTING SETTING	
-----	
SPEED: 5 IPS	Print speed (inch/sec)
DENSITY: 8.0	Print darkness
WIDTH: 4.00 INCH	Label size (inch)
HEIGHT: 4.00 INCH	Gap distance (inch)
GAP: 0.00 INCH	Gap/black mark sensor
INTENSION: 5	intension
CODEPAGE: 850	Code page
COUNTRY: 001	Country code
-----	

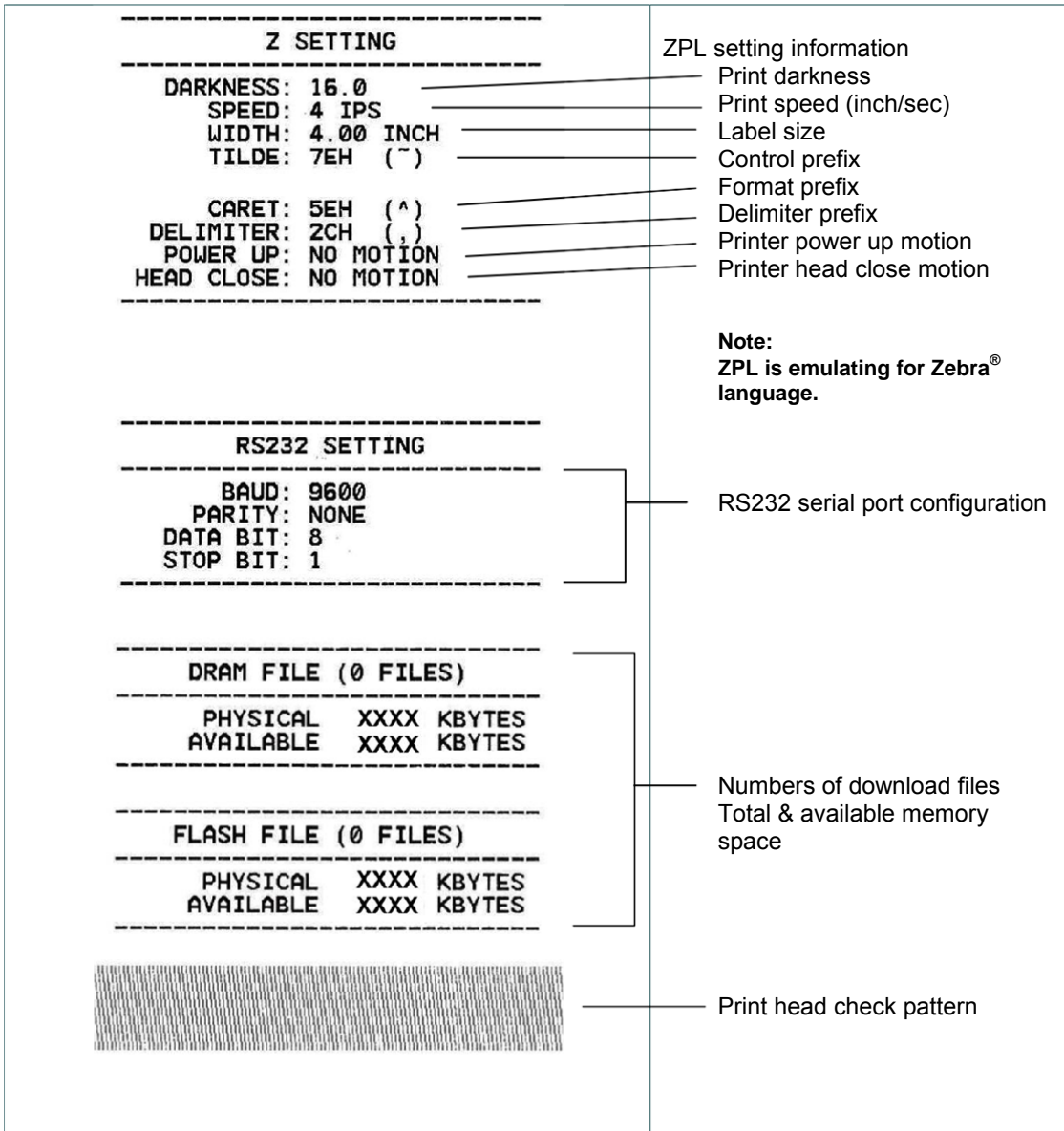

**Note:**  
Checking dot damage requires 4" wide paper width.

6.8.2 Dump Mode

Captures the data from the communications port and prints out the data received by printer. In the dump mode, all characters will be printed in 2 columns. The left side characters are received from your system and right side data are the corresponding hexadecimal value of the characters. It allows users or engineers to verify and debug the program.



```
DOWNLOA 0D 0A 44 4F 57 4E 4C 4F 4I
D „TEST2. 44 20 22 54 45 53 54 32 2E
DAT",5,CL 44 41 54 22 2C 35 2C 43 4C
S DOWNLO 53 0D 0A 44 4F 57 4E 4C 4F
AD F,"TES 41 44 20 46 2C 22 54 45 53
T4.DAT",5 54 34 2E 44 41 54 22 2C 35
,CLS DOW 2C 43 4C 53 0D 0A 44 4F 57
NLOAD „TE 4E 4C 4F 41 44 20 22 54 45
ST2.DAT", 53 54 32 2E 44 41 54 22 2C
5,CLS DO 35 2C 43 4C 53 0D 0A 44 4F
WNLOAD F, 57 4E 4C 4F 41 44 20 46 2C
„TEST4.DA 22 54 45 53 54 34 2E 44 41
T",5,CLS 54 22 2C 35 2C 43 4C 53 0D
DOWNLOAD 0A 44 4F 57 4E 4C 4F 41 44
"TEST2.D 20 22 54 45 53 54 32 2E 44
AT",5,CLS 41 54 22 2C 35 2C 43 4C 53
DOWNLOA 0D 0A 44 4F 57 4E 4C 4F 4I
D F,"TEST 44 20 46 2C 22 54 45 53 54
4.DAT",5, 34 2E 44 41 54 22 2C 35 2C
CLS 43 4C 53 0D 0A
```

**ASCII Data** (indicated by a red arrow pointing to the left column of the dump)

**Hexadecimal data related to left column of ASCII data** (indicated by a red arrow pointing to the right column of the dump)

**Note:**  
*Dump mode requires 4" wide paper width.*

6.8.3 Print Head

This feature is used to check print head's temperature, resistance and bad dots.



6.8.4 Display

This feature is used to check LCD's color state.



6.8.5 Sensor

This feature is used to check media sensor state.

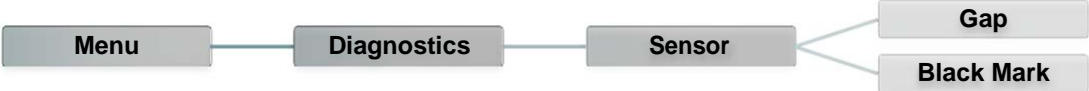

# 6.9 Advanced

This feature is used to set the printer LCD settings.

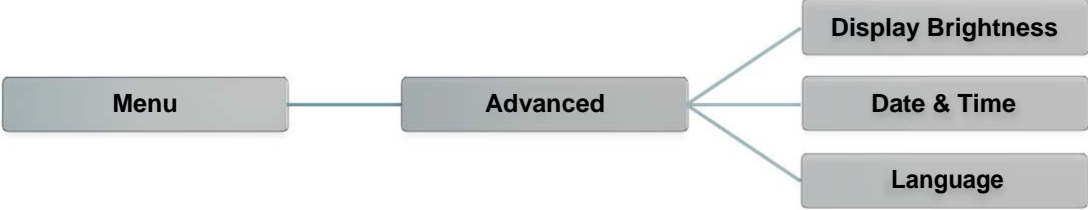

Item	Description
<b>Display Brightness</b>	This item is used to setup the brightness for display.
<b>Date &amp; Time</b>	This item is used to setup the date and time on display.
<b>Language</b>	This item is used to setup the language on display.

# 6.10 Service



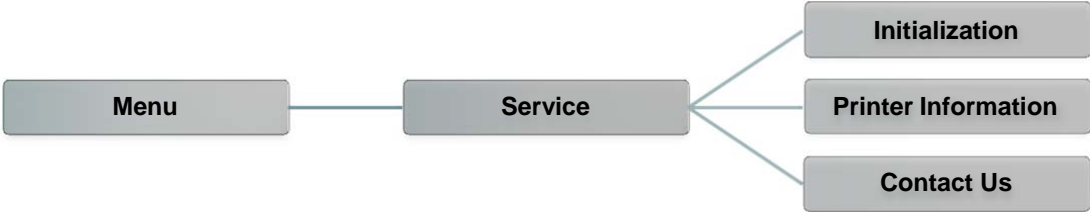



This feature is used to restore printer settings to defaults and checking information for printer.



Item	Description
<b>Initialization</b>	This feature is used to restore printer settings to defaults.
<b>Printer Information</b>	This feature is used to check the printer's serial number, printed mileage (m), printed labels (pcs.) and cutting counter.
<b>Contact Us</b>	This feature is used to check the contact information for tech support service.

## 7. Troubleshooting

The following guide lists the most common problems that may be encountered when operating this bar code printer. If the printer still does not function after all suggested solutions have been invoked, please contact the tech support service of your purchased reseller or distributor for assistance.

Problem	Possible Cause	Recovery Procedure
 <b>Power indicator does not illuminate</b>	* The power cord is not properly connected.	* Plug the power cord in printer and outlet. * Switch the printer on.
 <b>LED turn on (Carriage Open)</b>	* The printer head is open.	* Please close the print carriages.
 <b>LED turn on (No Ribbon)</b>	* Running out of ribbon. * The ribbon is installed incorrectly.	* Supply a new ribbon roll. * Please refer to the steps on section 3.2 to re-install the ribbon.
 <b>LED Blinking</b>	* Ribbon near end	* Supply a new ribbon roll.
 <b>LED turn on (No Paper)</b>	* Running out of label. * The label is installed incorrectly. * Gap/black mark sensor is not calibrated.	* Supply a new label roll. * Please refer to the steps on section 3.3 to reinstall the label roll. * Calibrate the gap/black mark sensor.
 <b>LED Blinking (Paper jam)</b>	* Gap/black mark sensor is not set properly. * Make sure label size is set properly. * Labels may be stuck inside the printer mechanism.	* Calibrate the media sensor. * Set media size correctly. * Remove the stuck label inside the printer mechanism.
 <b>LED turn on (Other errors)</b>	* Out of memory * Print head over heat * Cutter error/ Cutter jam	* Delete unused files in the FLASH/DRAM. * Wait for print head to cool down. * Remove the stuck label inside the cutter module.
<b>Not Printing</b>	* Check if interface cable is well connected to the interface connector. * Check if wireless or Bluetooth device is well connected between host and printer. * The port specified in the Windows driver is not correct.	* Re-connect cable to interface or change a new cable. * If using serial cable, - Please replace the cable with pin to pin connected. - Check the baud rate setting. The default baud rate setting of printer is 9600,n,8,1. * If using the Ethernet cable, - Check if the Ethernet RJ-45 connector green LED is lit on. - Check if the Ethernet RJ-45 connector amber LED is blinking. - Check if the printer gets the IP address when using DHCP mode. - Check if the IP address is correct when using the static IP address.

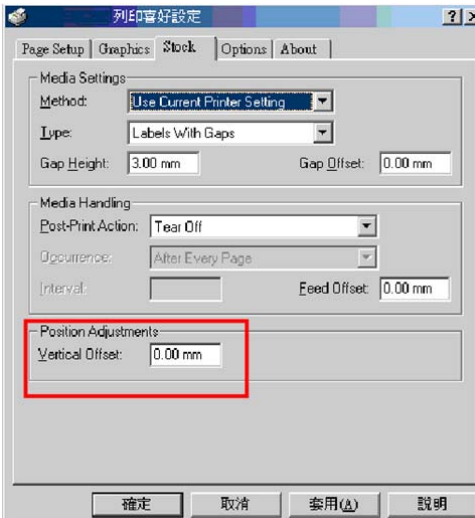

		<ul style="list-style-type: none"> <li>- Wait a few seconds let the printer get the communication with the server then check the IP address setting again.</li> <li>* Please reset the wireless device setting.</li> <li>* Select the correct printer port in the driver.</li> <li>* Print head's harness connector is not well connected with printhead. Turn off the printer and plug the connector again.</li> <li>* Check your program if there is a command PRINT at the end of the file and there must have CRLF at the end of each command line.</li> </ul>
<b>No print on the label</b>	<ul style="list-style-type: none"> <li>* Label or ribbon is loaded not correctly.</li> <li>* Use wrong type paper or ribbon</li> </ul>	<ul style="list-style-type: none"> <li>* Follow the instructions in loading the media and ribbon.</li> <li>* Ribbon and media are not compatible.</li> <li>* Verify the ribbon-inked side.</li> <li>* The print density setting is incorrect.</li> <li>* Clean the print head.</li> </ul>
<b>Poor Print Quality</b>	<ul style="list-style-type: none"> <li>* Ribbon and media is loaded incorrectly</li> <li>* Dust or adhesive accumulation on the print head.</li> <li>* Print density is not set properly.</li> <li>* Print head element is damaged.</li> <li>* Ribbon and media are incompatible.</li> <li>* The print head pressure is not set properly.</li> </ul>	<ul style="list-style-type: none"> <li>* Reload the supply.</li> <li>* Clean the print head.</li> <li>* Clean the platen roller.</li> <li>* Adjust the print density and print speed.</li> <li>* Run printer self-test and check the print head test pattern if there is dot missing in the pattern.</li> <li>* Change proper ribbon or proper label media.</li> <li>* The release lever does not latch the print head properly.</li> </ul>
<b>Take Label</b>	<ul style="list-style-type: none"> <li>* Peel function is enabled.</li> </ul>	<ul style="list-style-type: none"> <li>* If the peeler module is installed, please remove the label.</li> <li>* If there is no peeler module in front of the printer, please switch off the printer and install it.</li> <li>* Check if the connector is plugging correctly.</li> </ul>
<b>Cutter is not working</b>	<ul style="list-style-type: none"> <li>* The connector is loose.</li> <li>* Cutter jam.</li> <li>* Cutter PCB is damaged.</li> </ul>	<ul style="list-style-type: none"> <li>* Plug in the connect cable correctly.</li> <li>* Remove the label.</li> <li>* Make sure the thickness of label is less than 0.19 mm.</li> <li>* Replace a cutter driver IC board.</li> </ul>
<b>Can't downloading the file to memory (FLASH / DRAM/CARD)</b>	<ul style="list-style-type: none"> <li>* The space of memory is full.</li> </ul>	<ul style="list-style-type: none"> <li>* Delete unused files in the memory.</li> </ul>
<b>SD card is unable to use</b>	<ul style="list-style-type: none"> <li>* SD card is damaged.</li> <li>* SD card doesn't insert correctly.</li> <li>* Use the non-approved SD card manufacturer.</li> </ul>	<ul style="list-style-type: none"> <li>* Use the supported capacity SD card.</li> <li>* Insert the SD card again.</li> <li>* The supported SD card spec and the approved SD card manufacturers, please refer to section 2.2.3.</li> </ul>
<b>Missing printing on the left or right side of label</b>	<ul style="list-style-type: none"> <li>* Wrong label size setup.</li> </ul>	<ul style="list-style-type: none"> <li>* Set the correct label size.</li> </ul>
<b>Gray line on the blank label</b>	<ul style="list-style-type: none"> <li>* The print head is dirty.</li> <li>* The platen roller is dirty.</li> </ul>	<ul style="list-style-type: none"> <li>* Clean the print head.</li> <li>* Clean the platen roller.</li> </ul>

<p><b>Irregular printing</b></p>	<ul style="list-style-type: none"> <li>* The printer is in Hex Dump mode.</li> <li>* The RS-232 setting is incorrect.</li> </ul>	<ul style="list-style-type: none"> <li>* Turn off and on the printer to skip the dump mode.</li> <li>* Re-set the Rs-232 setting.</li> </ul>
<p><b>Label feeding is not stable (skew) when printing</b></p>	<ul style="list-style-type: none"> <li>* The media guides do not touch the edge of the media.</li> </ul>	<ul style="list-style-type: none"> <li>* If the label is moving to the right side, please move the label guide to left.</li> <li>* If the label is moving to the left side, please move the label guide to right.</li> </ul>
<p><b>Skip labels when printing</b></p>	<ul style="list-style-type: none"> <li>* Label size is not specified properly.</li> <li>* Sensor sensitivity is not set properly.</li> <li>* The media sensor is covered with dust.</li> </ul>	<ul style="list-style-type: none"> <li>* Check if label size is setup correctly.</li> <li>* Calibrate the sensor by Auto Gap or Manual Gap options.</li> <li>* Clear the GAP/Black mark sensor by blower.</li> </ul>
<p><b>Wrinkle Problem</b></p>	<ul style="list-style-type: none"> <li>* Printhead pressure is incorrect.</li> <li>* Ribbon installation is incorrect.</li> <li>* Media installation is incorrect.</li> <li>* Print density is incorrect.</li> <li>* Media feeding is incorrect.</li> </ul>	<ul style="list-style-type: none"> <li>* Please set the suitable density to have good print quality.</li> <li>* Make sure the label guides touch the edge of the media guide.</li> </ul>
<p><b>RTC time is incorrect when reboot the printer</b></p>	<ul style="list-style-type: none"> <li>* The battery has run down.</li> </ul>	<ul style="list-style-type: none"> <li>* Check if there is a battery on the main board.</li> </ul>
<p><b>The printing position of small label is incorrect</b></p>	<ul style="list-style-type: none"> <li>* Media sensor sensitivity is not set properly.</li> <li>* Label size is incorrect.</li> <li>* The parameter Shift Y is incorrect.</li> <li>* The vertical offset setting in the driver is incorrect.</li> </ul>	<ul style="list-style-type: none"> <li>* Calibrate the sensor sensitivity again.</li> <li>* Set the correct label size and gap size.</li> <li>* Use DiagTool to fine tune the parameter of Shift Y.</li> <li>* If using the software BarTender, please set the vertical offset in the driver.</li> </ul>  <p>The screenshot shows the 'Media Settings' dialog box in the BarTender software. The 'Method' is set to 'Use Current Printer Setting', 'Type' is 'Labels With Gaps', 'Gap Height' is 3.00 mm, and 'Gap Offset' is 0.00 mm. Under 'Media Handling', 'Post-Print Action' is 'Tear Off', 'Occurrence' is 'After Every Page', and 'Feed Offset' is 0.00 mm. Under 'Position Adjustments', the 'Vertical Offset' is set to 0.00 mm, which is highlighted with a red box.</p>

## 8. Maintenance

This session presents the clean tools and methods to maintain your printer.

1. Please use one of following material to clean the printer.

- Cotton swab
- Lint-free cloth
- Vacuum / Blower brush
- 100% Ethanol or Isopropyl Alcohol

2. The cleaning process is described as following,

Printer Part	Method	Interval
<b>Print Head</b>	1. Always turn off the printer before cleaning the print head. 2. Allow the print head to cool for a minimum of one minute. 3. Use a cotton swab and 100% Ethanol or Isopropyl Alcohol to clean the print head surface.	Clean the print head when changing a new label roll.
<b>Platen Roller</b>	1. Turn the power off. 2. Rotate the platen roller and wipe it thoroughly with water.	Clean the platen roller when changing a new label roll
<b>Peel Bar</b>	Use the lint-free cloth with 100% ethanol to wipe it.	As needed
<b>Sensor</b>	Compressed air or vacuum	Monthly
<b>Exterior</b>	Wipe it with water-dampened cloth	As needed
<b>Interior</b>	Brush or vacuum	As needed

**Note:**

- Do not touch printer head by hand. If you touch it careless, please use ethanol to clean it.
- Please use 100% Ethanol or Isopropyl Alcohol. DO NOT use medical alcohol, which may damage the printer head.
- Regularly clean the print head and supply sensors once change a new media to keep printer performance and extend printer life.

## Revise History

---

Date	Content	Editor
2015/4/15	Modify the pictures for moved parts color (green)	Camille
2015/4/20	Modify section 3.2 (Printhead module change)	Camille
2015/10/16	Modify section 1.2.1(Add the ribbon encoder sensor info.)	Camille
2015/10/21	Modify section 2.2.3(Recommended SD card specification)	Camille
2016/5/5	Add section 6.8.5 (Sensor)	Camille
2016/7/5	Add note for peel-off module on chapter 1.2.2 & 3.3.3	Camille
2017/3/22	Modify section 1.2.2	Camille
2017/6/29	Add the cautions on ch. 2.2.2 & ch.2.2.3	Camille
2017/7/6	Update printer specifications	Camille
2018/1/23	Update Agency Compliance and Approvals	Kate



**Wasp Barcode Technologies**

Corporate Headquarters

1400 10th St Plano,

TX 75074

TEL: 214-547-4100

Website: [www.waspbarcode.com](http://www.waspbarcode.com)

E-mail: [support.waspbarcode.com](mailto:support.waspbarcode.com)